

706564-602	DARK BROWN
706564-603	LIGHT BROWN
706564-604	GREY

FINNO

137415M







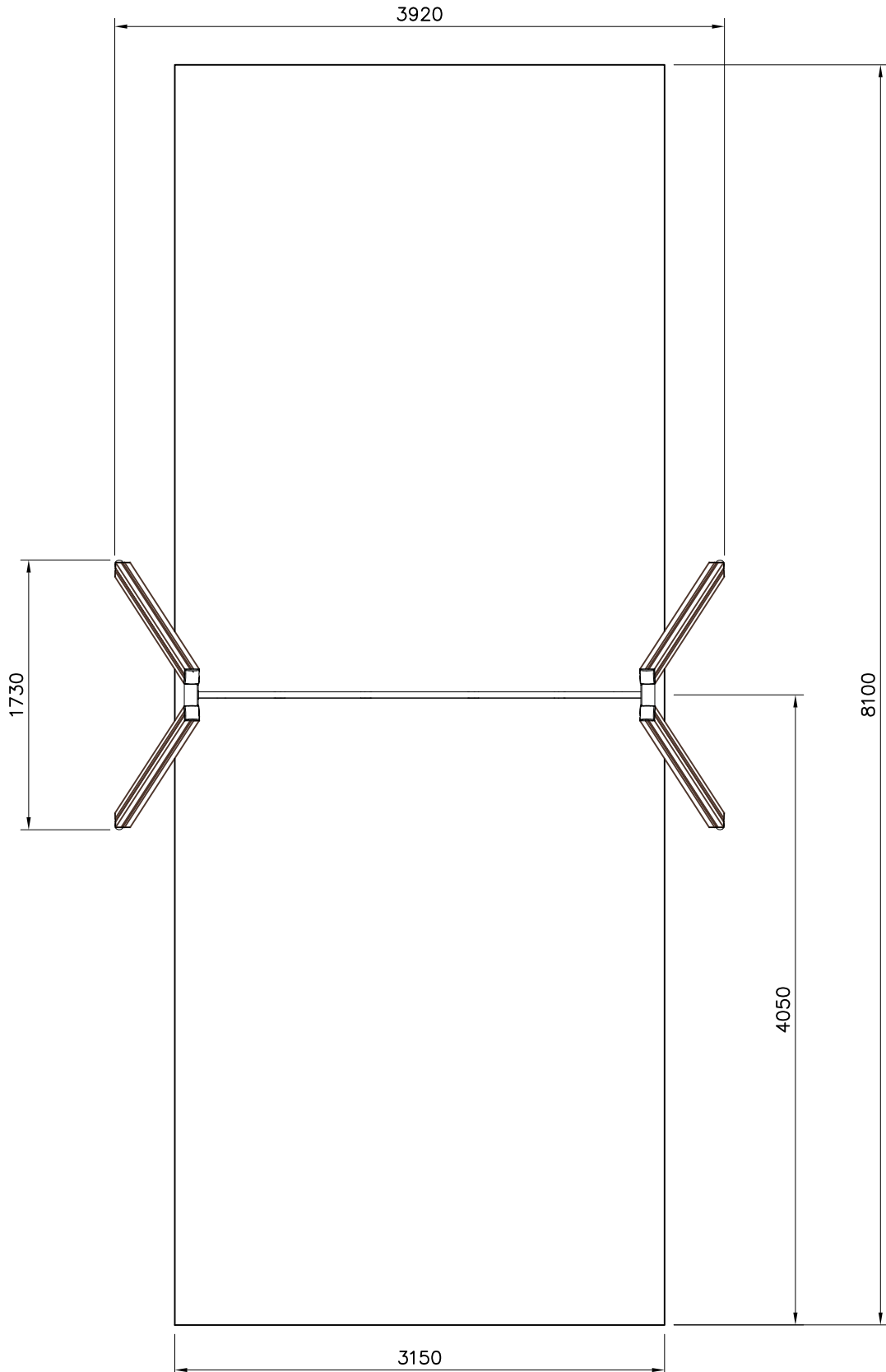

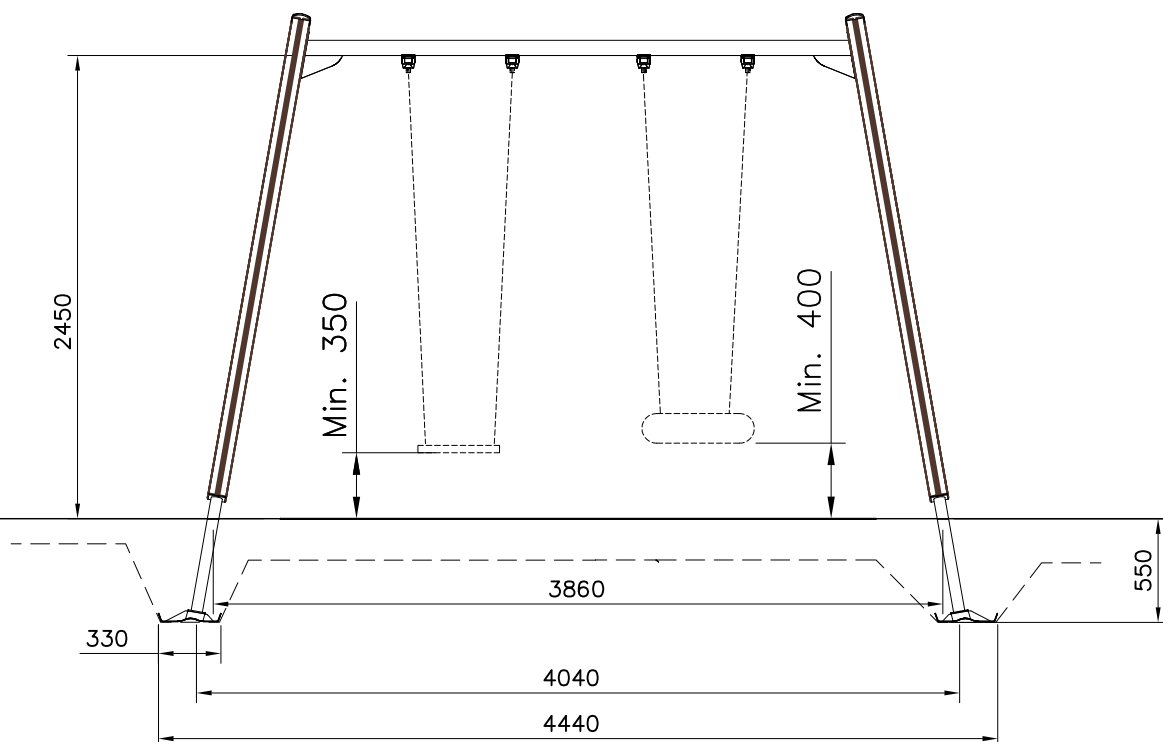
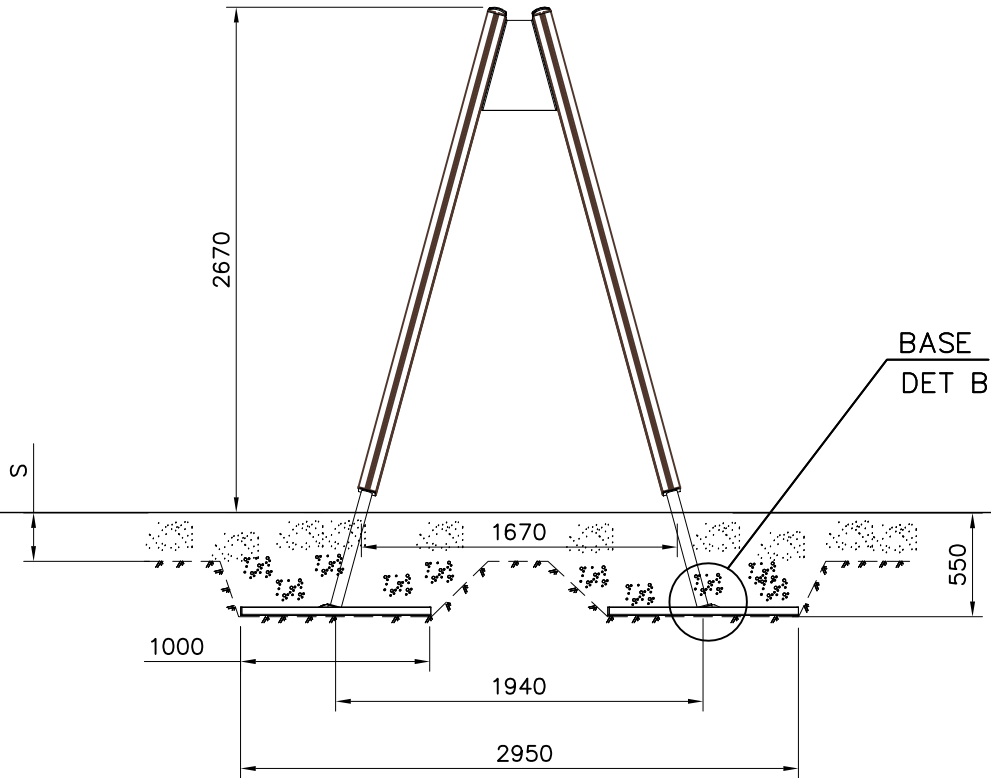

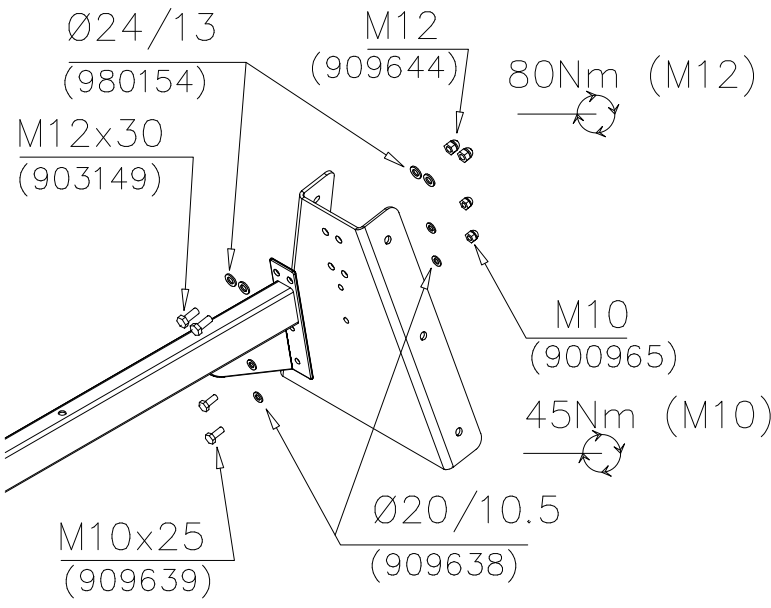
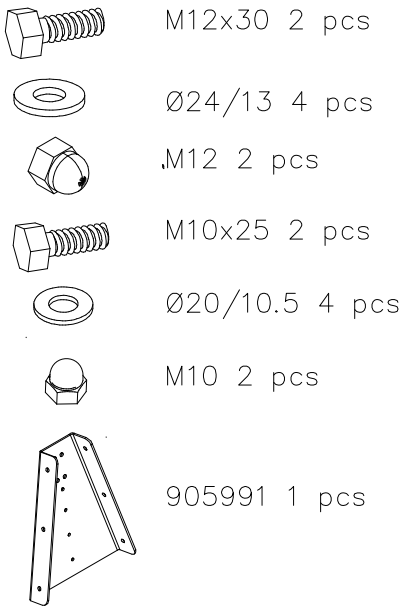
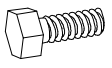

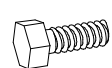

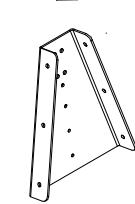
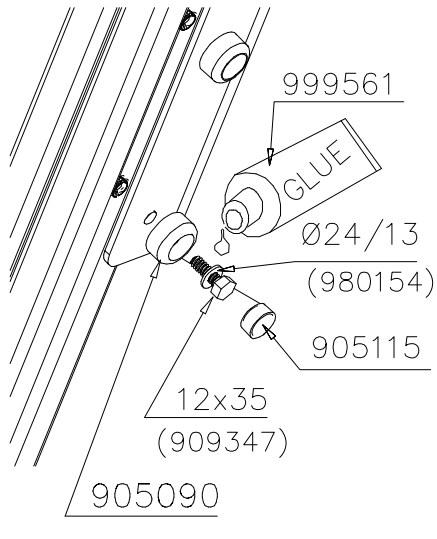

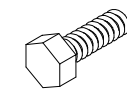
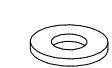
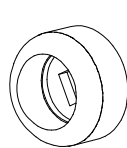
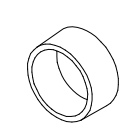

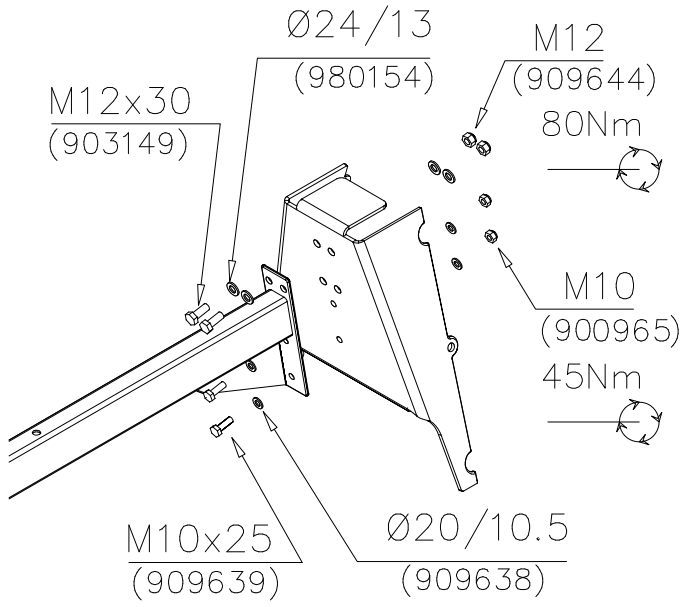
DATE: 19.10.2015



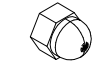

- EN Impact Area 25.5 m²
- Falling space 25.5 m²
- Max falling height 1400 mm

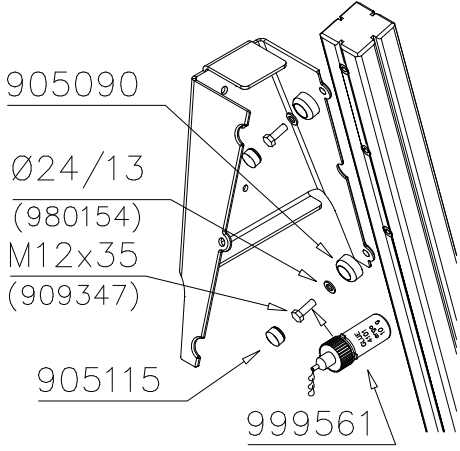

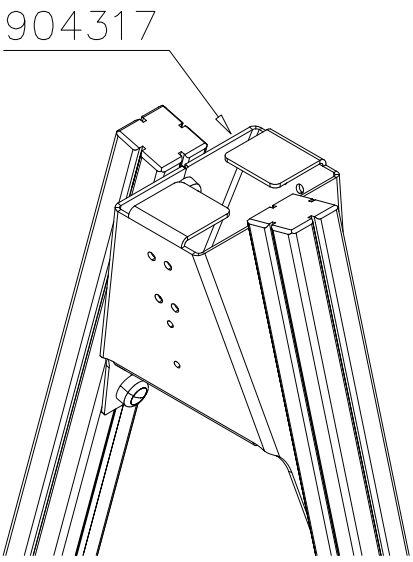
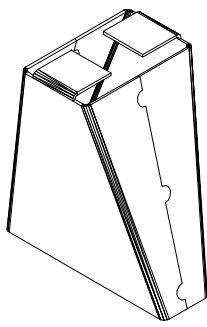
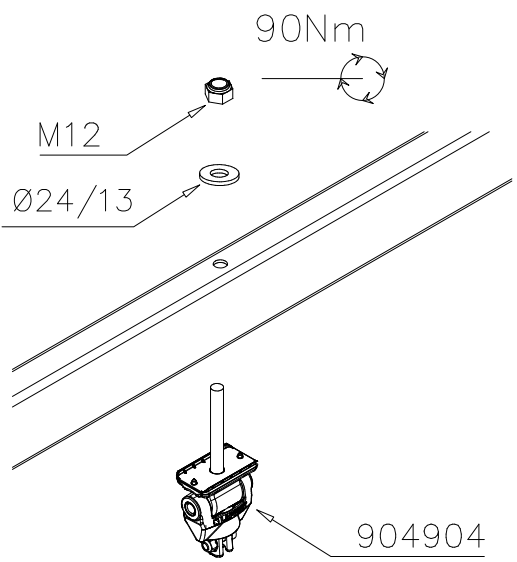
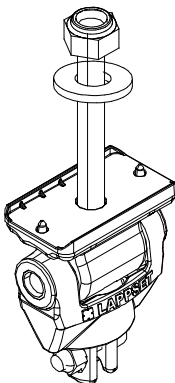

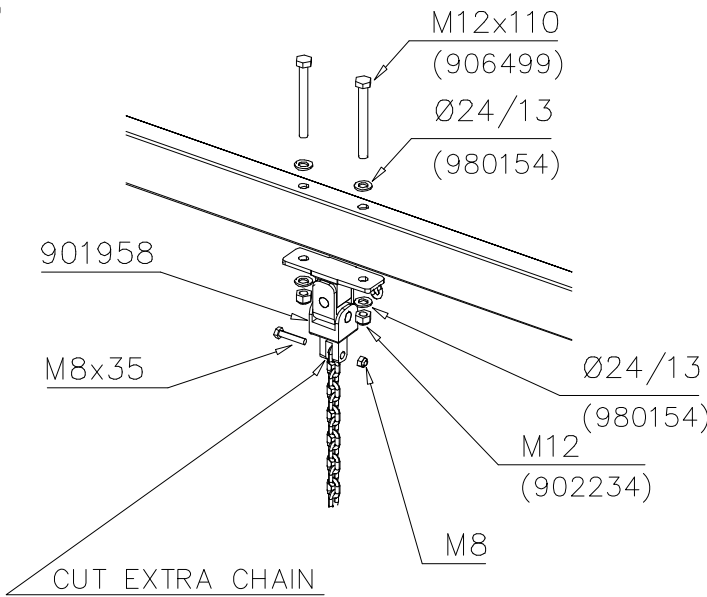

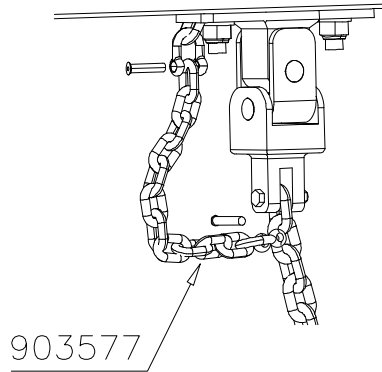
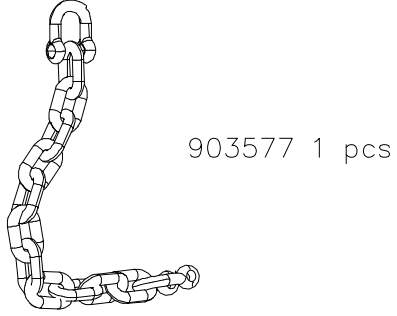
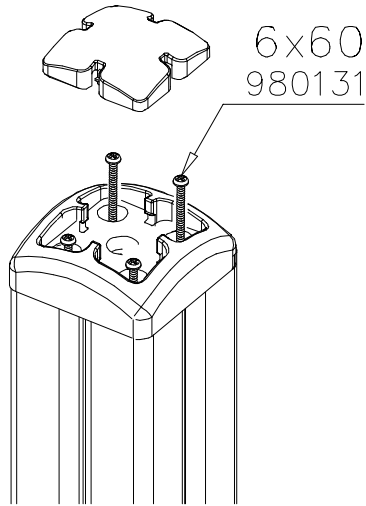

<p>DET A</p>  <p>Ø24/13 (980154) M12 (909644) 80Nm (M12) M12x30 (903149) M10 (900965) 45Nm (M10) M10x25 (909639) Ø20/10.5 (909638)</p>	 <ul style="list-style-type: none">  M12x30 2 pcs  Ø24/13 4 pcs  M12 2 pcs  M10x25 2 pcs  Ø20/10.5 4 pcs  M10 2 pcs  905991 1 pcs
<p>DET A</p>  <p>999561 GLUE Ø24/13 (980154) 905115 12x35 (909347) 905090</p>	 <ul style="list-style-type: none">  M12x35 6 pcs  Ø24/13 6 pcs  Ø45 6 pcs  Ø30 6 pcs  GLUE
<p>DET B</p>  <p>Ø24/13 (980154) M12 (909644) 80Nm M12x30 (903149) M10 (900965) 45Nm M10x25 (909639) Ø20/10.5 (909638)</p>	 <ul style="list-style-type: none">  M12x30 2 pcs  Ø24/13 4 pcs  M12 2 pcs  M10x25 2 pcs  Ø20/10.5 4 pcs  M10 2 pcs

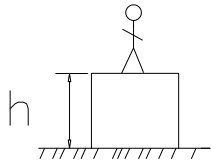
<p>DET B</p> 	
<p>DET B</p> 	 <p>904317</p>
<p>DET C</p> 	 <p>904904</p>

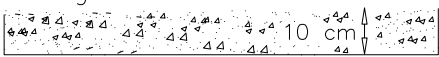
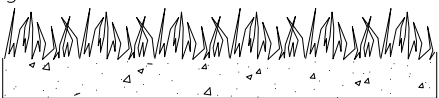
<p>DET D</p>  <p>M12x110 (906499) Ø24/13 (980154)</p> <p>901958</p> <p>M8x35</p> <p>Ø24/13 (980154)</p> <p>M12 (902234)</p> <p>M8</p> <p>CUT EXTRA CHAIN</p>	 <p>M12x110 2 pcs</p> <p>Ø24/13 4 pcs</p> <p>M12 2 pcs</p> <p>901958 1 pcs</p>
<p>DET D</p>  <p>903577</p>	 <p>903577 1 pcs</p>
<p>DET E</p>  <p>6x60 980131</p>	 <p>980131 4 pcs</p> <p>905138 1 pcs</p> <p>905196 1 pcs</p>

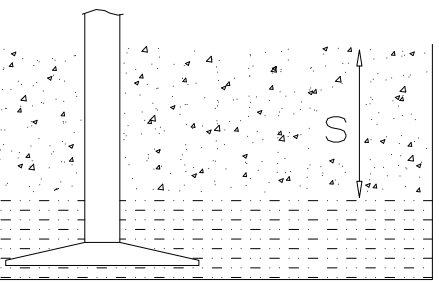
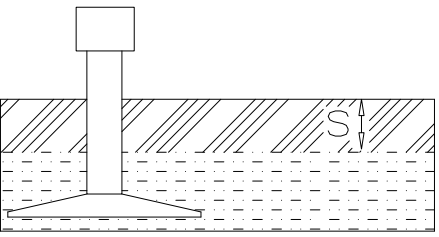
												
<p>$h < 600$</p> <p>Without movement and therefore without Impact Area</p>	<p>Totally hard surfaces.</p> <p>Note. Lappset does <u>not recommend</u> totally hard surfaces at all.</p>	<p>E.g. concrete or asphalt</p> 										
<p>$h < 600$</p> <p>With movement e.g. rocking</p>	<p>Materials with very limited impact attenuating properties.</p>	<p>E.g. wood</p> 										
<p>$h < 1000$</p>	<p>Materials with significant impact attenuating properties.</p>	<p>fine gravel 0–8 mm</p>  <p>grass</p>  <p>unsorted sand</p> 										
<p>$h < 3000$</p>	<p>Loose fill material</p> <p>E.g. sand/gravel 0,25...8 mm D60/D10<3,0 Woodchips 5...30 mm bark 20...80 mm</p>	 <table data-bbox="1018 1653 1332 1751"> <tr> <td>\underline{S}</td> <td>\underline{h}</td> </tr> <tr> <td>30 cm</td> <td>< 2,0 m</td> </tr> <tr> <td>40 cm</td> <td>< 3,0 m</td> </tr> </table>	\underline{S}	\underline{h}	30 cm	< 2,0 m	40 cm	< 3,0 m				
\underline{S}	\underline{h}											
30 cm	< 2,0 m											
40 cm	< 3,0 m											
	<p>Syntethic granulates</p> <table data-bbox="406 1859 758 2027"> <tr> <td>\underline{S}</td> <td>\underline{h}</td> </tr> <tr> <td>40 mm</td> <td>~> 1,2...1,3 m</td> </tr> <tr> <td>50 mm</td> <td>~> 1,5...1,7 m</td> </tr> <tr> <td>60 mm</td> <td>~> 1,8...2,0 m</td> </tr> <tr> <td>70 mm</td> <td>~> 2,1...2,5 m</td> </tr> </table> <p>Note. For accurate values, see manufacturer's instructions.</p>	\underline{S}	\underline{h}	40 mm	~> 1,2...1,3 m	50 mm	~> 1,5...1,7 m	60 mm	~> 1,8...2,0 m	70 mm	~> 2,1...2,5 m	
\underline{S}	\underline{h}											
40 mm	~> 1,2...1,3 m											
50 mm	~> 1,5...1,7 m											
60 mm	~> 1,8...2,0 m											
70 mm	~> 2,1...2,5 m											

REMOVE SAFETY SURFACE/SAND/GRAVEL
TO CHECK FOUNDATION

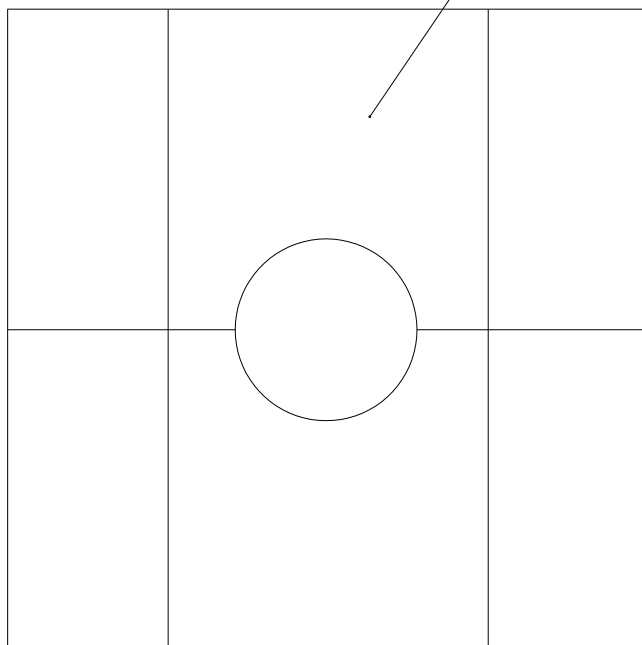

REMOVE SAFETY SURFACE/SAND/GRAVEL
TO CHECK FOUNDATION

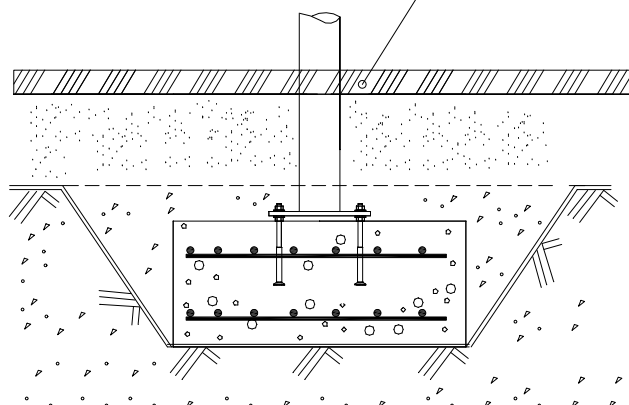

DET A

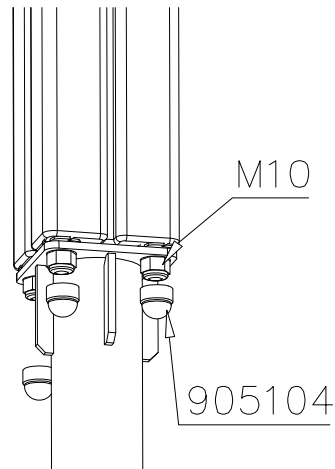

DET B

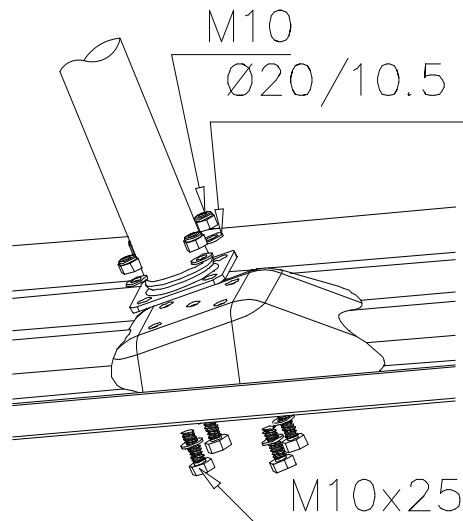

DET B

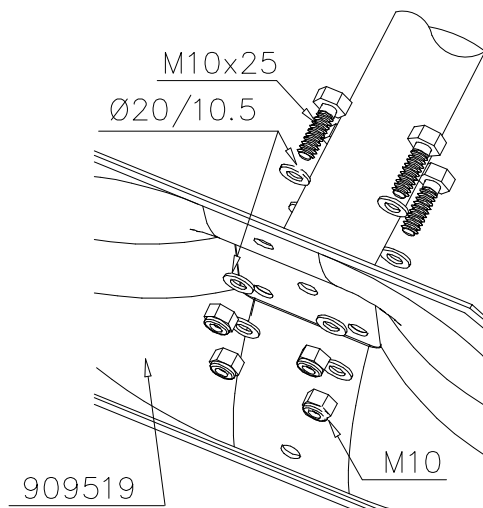

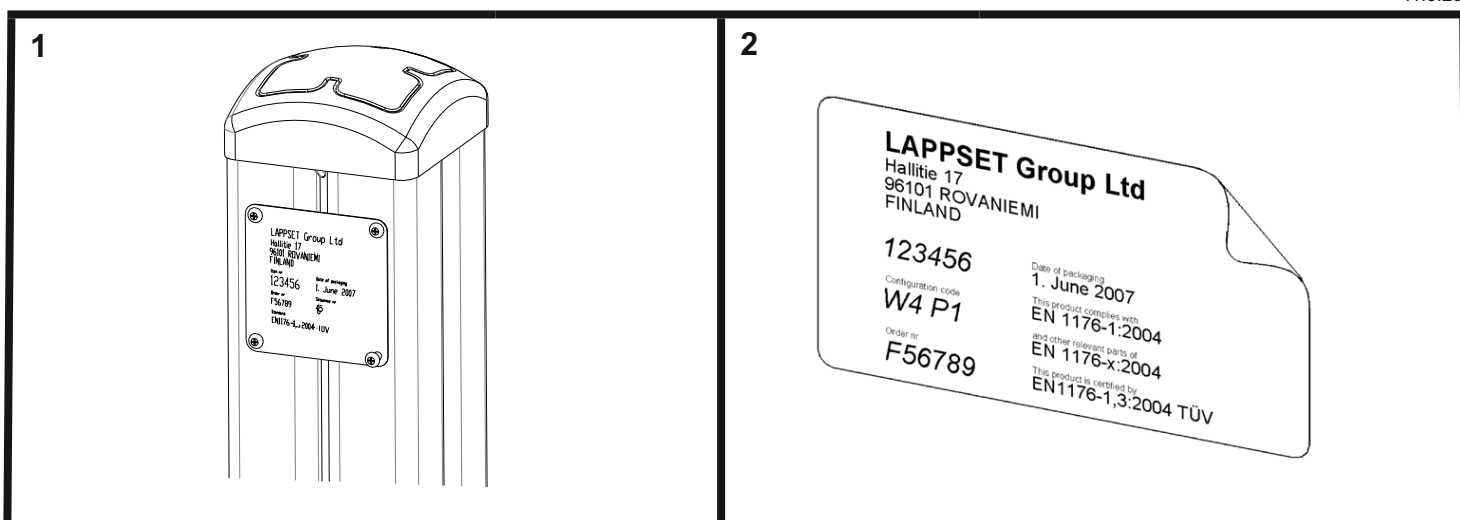

Tuotekyltti tulee tuotteen mukana yhdellä seuraavista tavoista:

1) Metallinen tuotekyltti ja kiinnitysruuvit

- Kiinnitä tuotekyltti ruuveilla tolppaan noin 2 metrin korkeuteen kuvan 2 mukaisesti.

2) Tuotekylttitarra

- Puhdista maalattu metalli- tai vaneripinta pölystä ja kosteudesta. Liimaa tarra kuvan 3 mukaisesti.
- Huom. Älä kiinnitä tarraa karheapintaiseen laminaattiin tai maalattuun puuhun.

Vår produktmärkning levereras på ett av följande sätt:

1) Produktskylt i metall

- Fäst skylten med de medföljande skruvarna

2) Självhäftande produktetikett

- Rengördenpulverlackerademetallytanellerlaminatytansåttndenblirfrifrånsmutsochfukt.Fästetikettenenligtfig.3.
- Obs! Fäst ej etiketten på detaljer med skrovlig yta eller på målat trä.

Product label is delivered by one of following ways:

1) Metal product label and screws

- Fasten the label with screws.

2) Label sticker

- Cleanthepaintedmetalorplywoodsurfacefromdirtandmoisture.Fastenthestickerasshowninthefigure3.
- Note. Do not attach the sticker to rough surfaced laminate or painted wood.

La plaque d'informations produit est livrée sous l'une de ces 3 formes :

1) Plaque métallique et vis

- Fixez la plaque à l'aide des vis.

2) Etiquette autocollante

- Avant de coller l'étiquette, nettoyez le composant métallique peint ou la plaque de contreplaqué, de toute saleté. La surface doit être sèche (voir image 3).
- Attention, ne pas coller l'étiquette sur une surface lamellé-collée irrégulière ou sur du bois peint.

Die Auslieferung des Produktaufklebers erfolgt auf eine dieser Arten:

1) Produkt-Schild aus Metall incl. Schrauben

- Die Befestigung des Schildes erfolgt mittels der Schrauben.

2) Aufkleber

- EntfernenSiezunächstSchmutzundFeuchtigkeitvomlackiertenMetallbzw.vonderHolzoberflächeundbringenSiedenAufkleber wie im Bild oben rechts beschrieben auf den gesäuberten Untergrund auf.
- Beachten Sie: Bringen Sie den Aufkleber nicht auf raues laminiertes oder lackiertes Holz an.