

Lumi Plus



- **Total Height** – 817 mm; 32.16”
- **Body Length** – 637 mm; 25.07”
- **Body Width** – 400 mm; 15.7”
- **Max. Fall Height** – 594 mm; 23.38”
- **Min. Under surfacing Requirements Area** - 5 sqm (2.64 m x 2.4 m)
- **Capacity** – 1 person
- **Shipping Weight** – 26 kg / 58 lb
- **Shipping Dimensions** – 800mm/650mm/410mm
- **Shipping Dimensions inches** – 31”/26”/16”
- **Fundament**– 1 concrete fundament





 reddot design award
 winner 2017





Features



 **Light** – LED lights powered by our proprietary kinetic generator

 **Reporting data** of usage and condition (IoT)

 **Remote control** - of fountains, art installations, lights and others

 **Interactive communication between devices** - using the data we gather we can hold playing competitions between different playgrounds

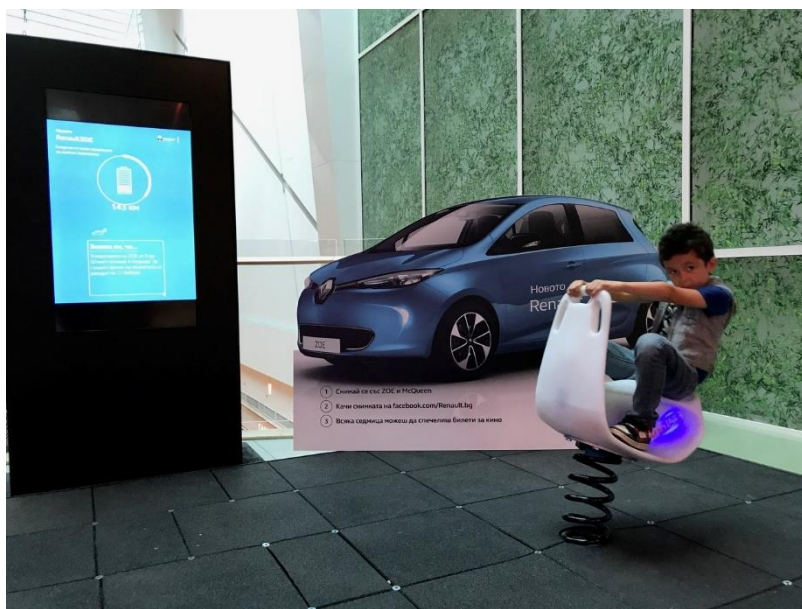

Materials



- **Fixing** – Galvanized steel
- **Spring** – Powder – coated steel (with options of galvanization)
- **Footing** – Galvanized steel



- **Body** - LDPE (Low-density polyethylene) rotational molded body with integrated LED lights and kinetic generator

Fundamentals



Installation

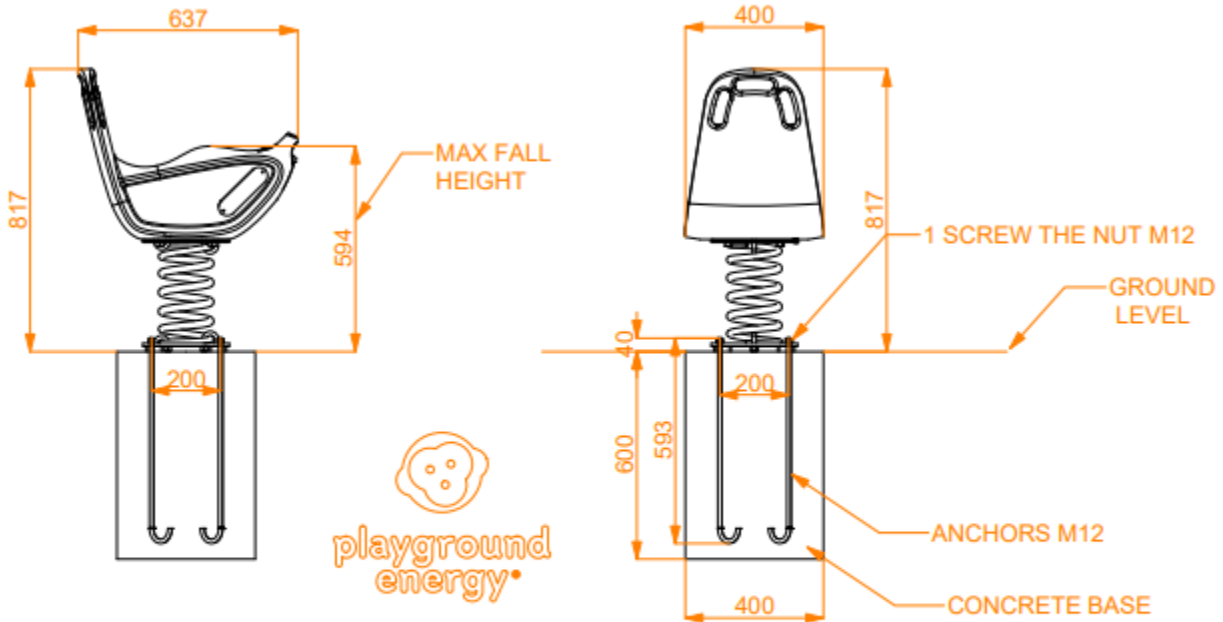

LUMI plus

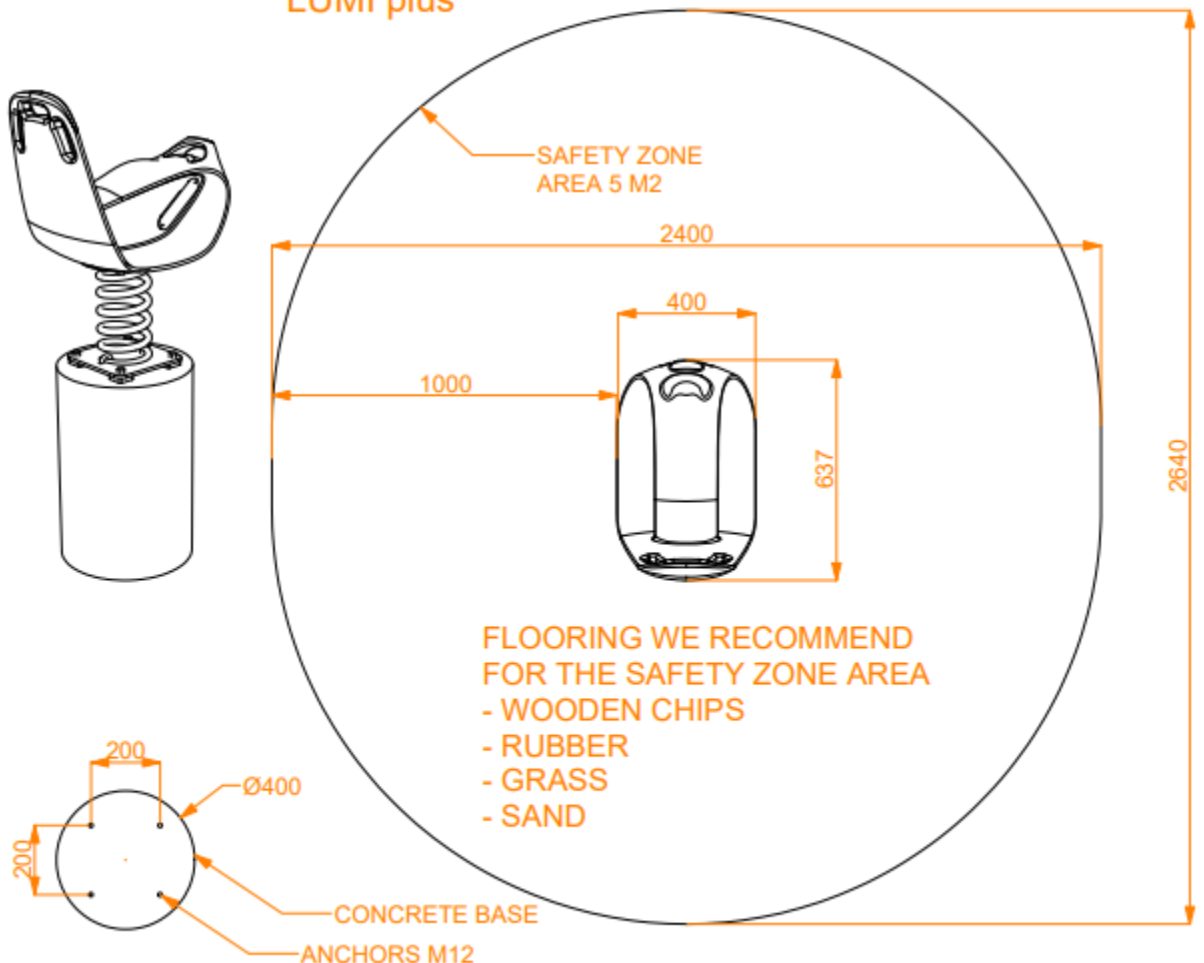

Safety zones

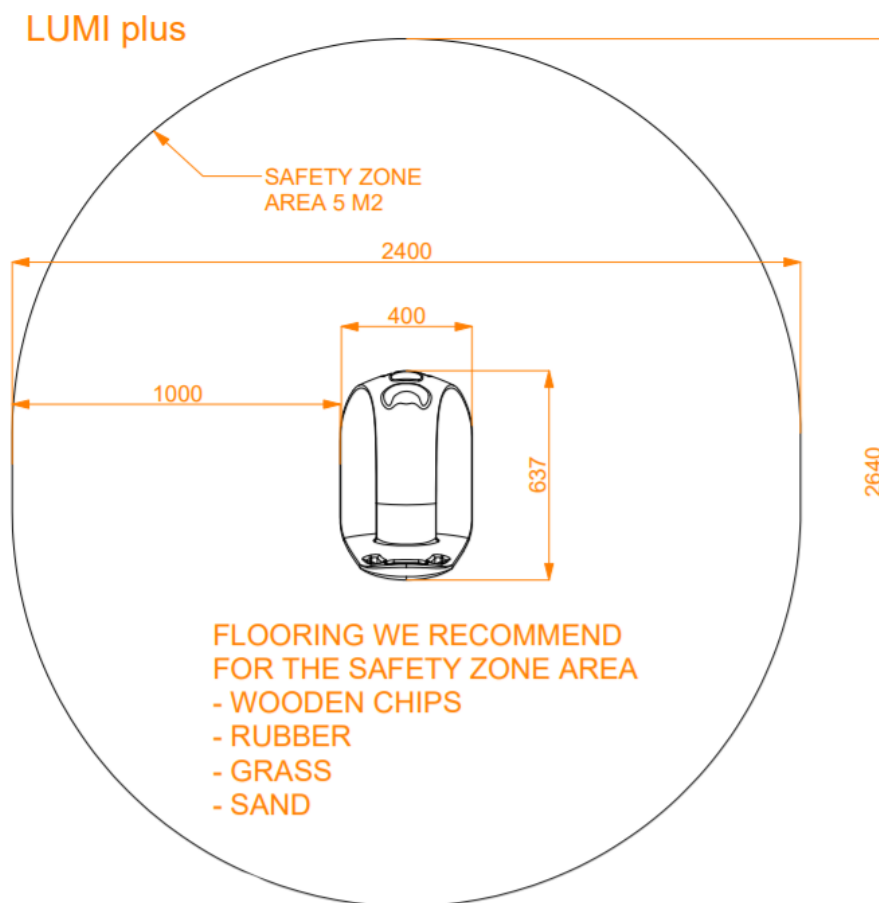

Rocking equipment „LUMI PLUS“, model: 2016 01, designed according to the requirements of EN 1176 – 1:2017 and EN 1176 – 6:2017, is children's rocking equipment with support at one point and movement in many directions. Support - steel coil spring operating on tension and compression.

On the figure above the basic technical data of the product are specified as free fall height – 59 cm, space for falling, location of the information plate and recommended types of surfacing for the place of falling. This rocking equipment is intended for independent use by children in the 3 - 12 age range.

Product Specifications

Certificates

CERTIFICATE

Certificate ID: 18P3.0051.0

Certificate holder: Playground Energy Ltd.
5 Hristo Chernopeev str., en. A, ap.12
1113 Sofia, BULGARIA

Manufacturer: Playground Energy Ltd.
5 Hristo Chernopeev str., en. A, ap.12
1113 Sofia, BULGARIA

Certificate requirements: БДС EN 1176 - 1:2017
БДС EN 1176 - 6:2017

This certification is based on testing and assessment of conformity referred to in Report № 18P3.0051.0 - R01.06.12.2018

Product: PLAYGROUND EQUIPMENT

Identification: Models: Lumi Plus
Type: Rocket, 2A
Age group: 3+ years;
Free height of fall: 50 cm;

Sofia, 10.12.2018

TÜV RHEINLAND - BULGARIA EOOD
1113 Sofia, 23A Dragan Tsankov Blvd.

*Product Certification Body with TÜV Rheinland Bulgaria EOOD. Accredited by EA "BAE" in accordance with EN ISO/IEC 17065, reg. No. 19-007

www.tuv.com

 TÜVRheinland®
Precisely Right.

Certificate

Standard: BDS EN ISO 9001:2008

Certificate Registr. No. TRBA 100 0972

TÜV RHEINLAND-BULGARIA EOOD certifies:

Certificate Holder: PLAYGROUND ENERGY Ltd.
BG-1113 Sofia
5 Hristo Chernopeev Str.
Bulgaria



Scope: Design, assembly and sales of equipment for playground, parks and sports facilities.

An audit was performed, Report No. 0972. Proof has been furnished that the requirements according to BDS EN ISO 9001:2015 are fulfilled.

Validity: The certificate is valid from 02.04.2017 until 14.09.2018.
First certification: 2014

31.03.2017



TÜV RHEINLAND-BULGARIA EOOD
1113 Sofia, 23A Dragan Tsankov Blvd.

www.tuv.com

 TÜVRheinland®
Precisely Right.



WINAM GROUP

Room 101, 226 / 4A Le Trong Tan, Tay Thanh Ward, Tan
Phu District, Ho Chi Minh City, Viet Nam

(028) 22 494 333

info@playground.com.vn | www.playground.com.vn