









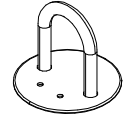
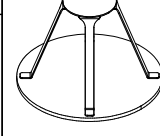

① 702286	PCS	② 703061	PCS
	1		1
90x50		850x776x20	
③ 906176	PCS	④ 705101	PCS
	1		1
			
⑤ 903192	PCS	⑥ 903870	PCS
	1		3
20x200		M10x40	
		⑦ 903191	PCS
			2
		M10x35 (902252)	
			
		Ø20/10.5x2 (901302)	PCS
			
		M10 (909637)	
			
		19x21x25 (903193)	
	PCS		PCS
	PCS		PCS
	PCS		PCS

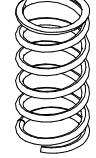
DET 705101 OPTIO 1

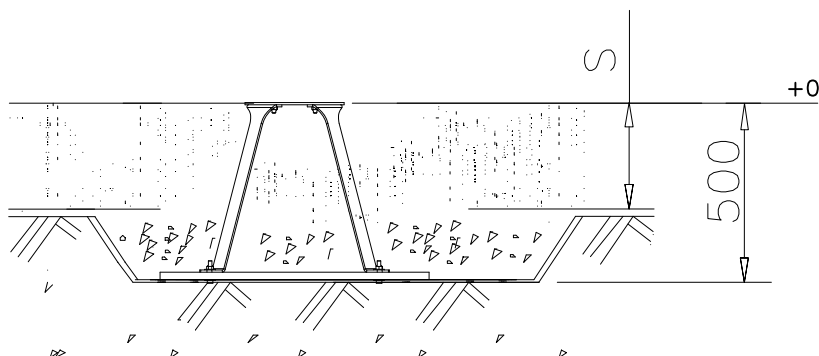

# WINAM GROUP

## CLOXX

# 220013M

DATE: 9.1.2018

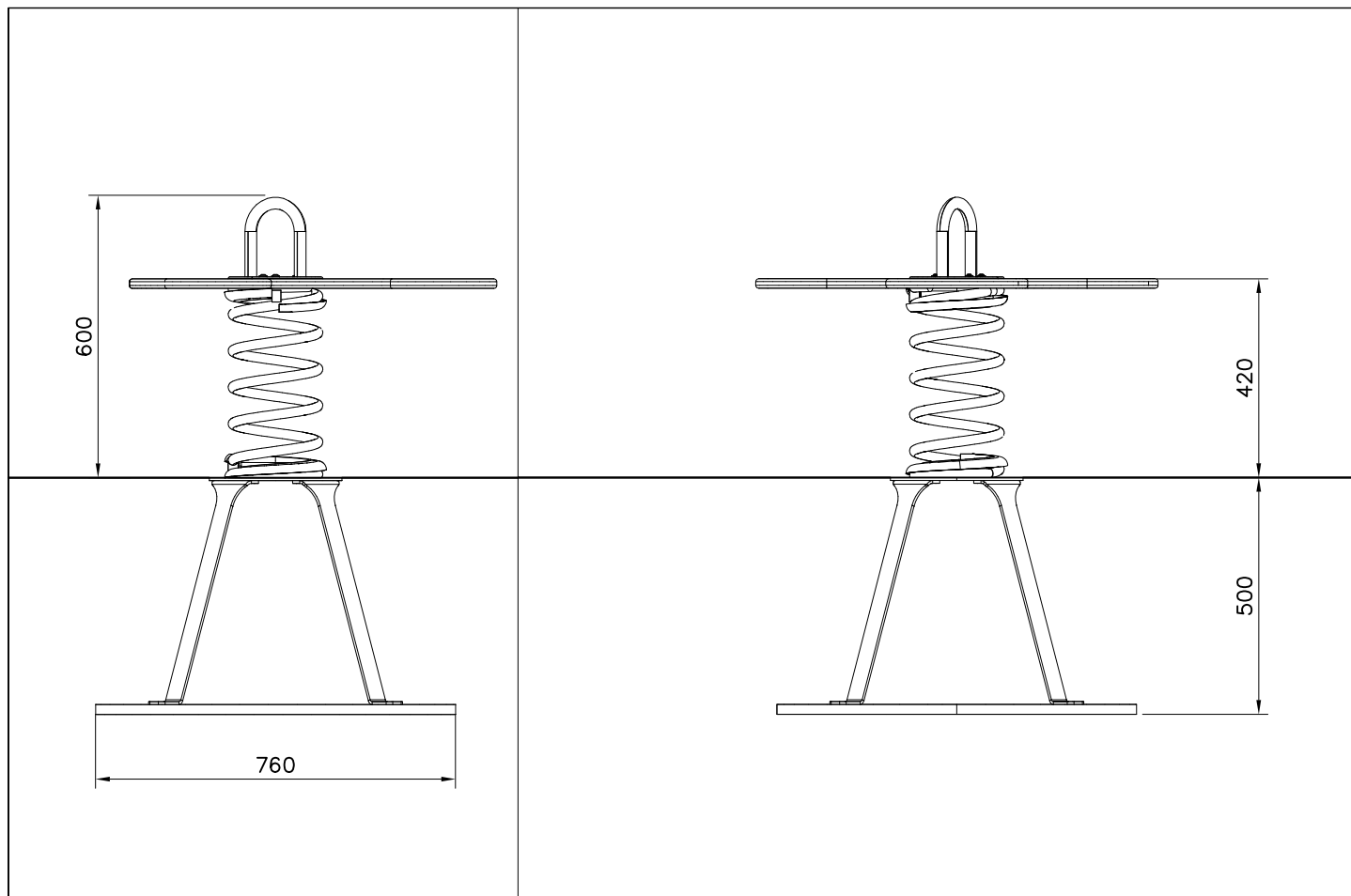

- EN Impact Area 6.7 m<sup>2</sup>
- - - Falling Space 6.7 m<sup>2</sup>
- Max Falling Height 600 mm

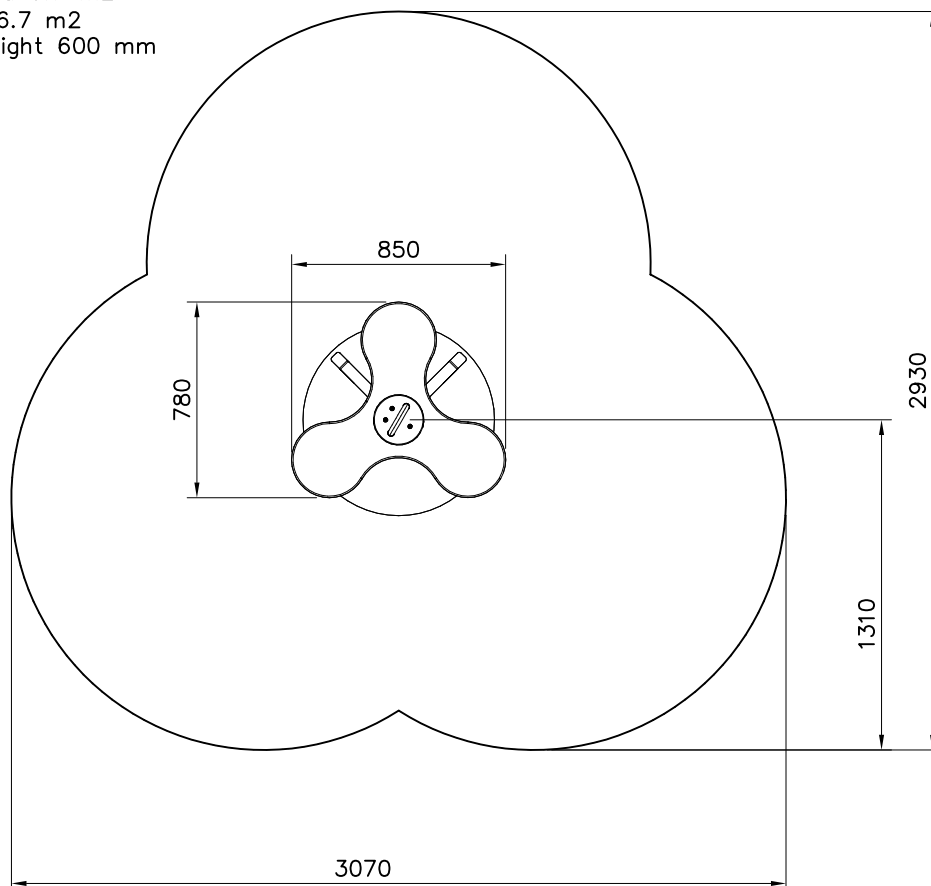

JOLI CLOXX OPTION PLATES	24.6.2009
--------------------------	-----------

PRODUCT	SIZE	YEL	RED	DARK GRA	LIGHT GRA
220012M	1034x310x20	No	702443	703059	No
220013M	850x776x20	No	702396	703061	No
220031M	Ø350x15	No	702846	702844	No
	Ø200x15	No	No	702845	No
220032M	Ø350x15	No	702846	702844	No
	Ø200x15	No	No	702845	No
220033M	Ø1200x20	No	No	702852	703060
	850x776x15	703058	702850	No	No

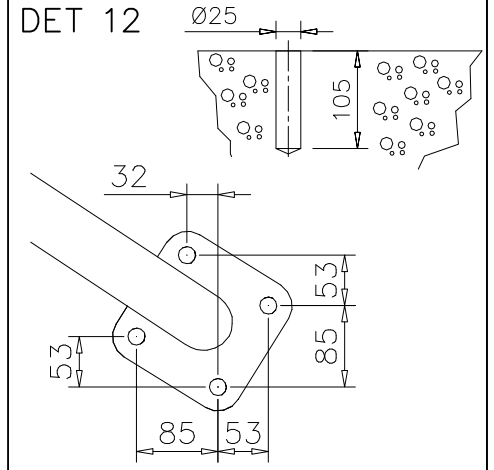
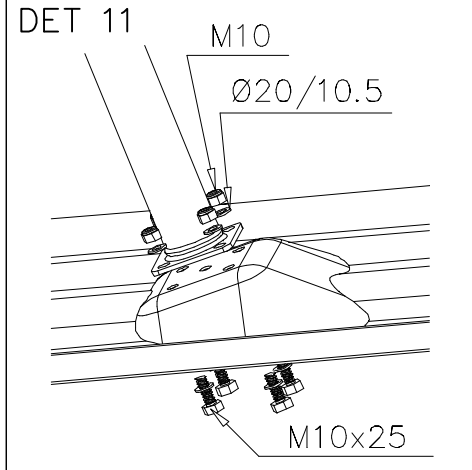
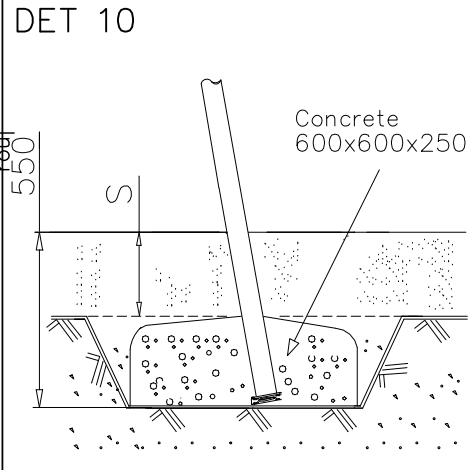
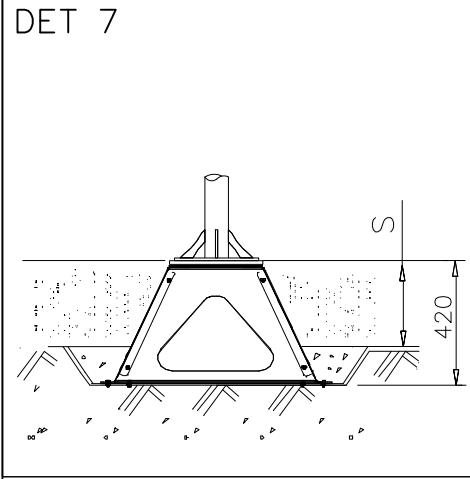
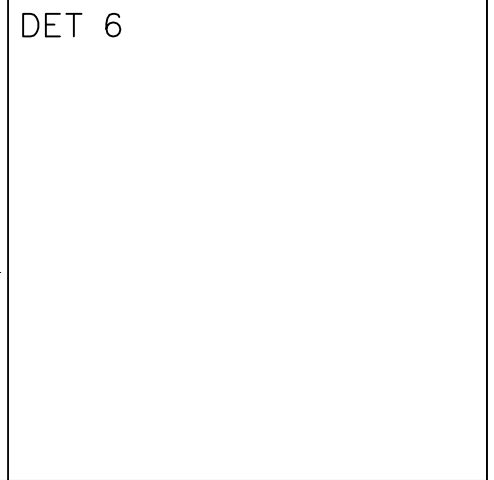
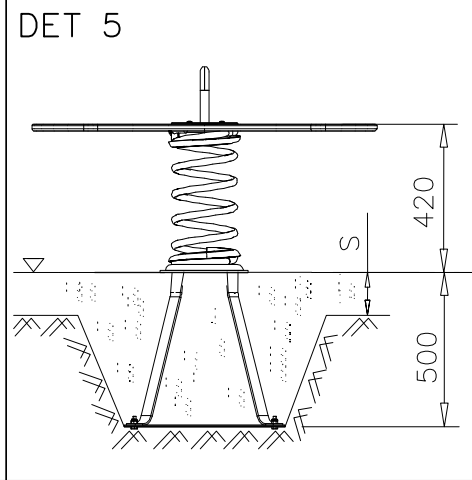
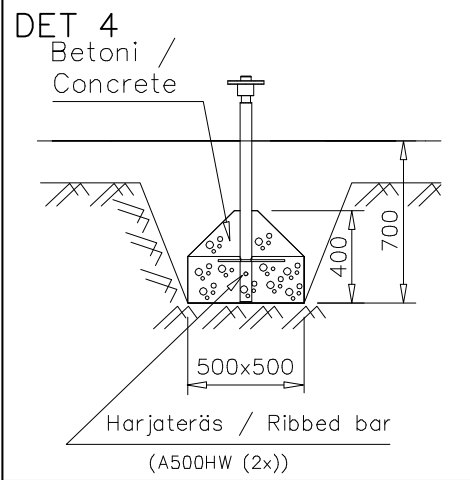
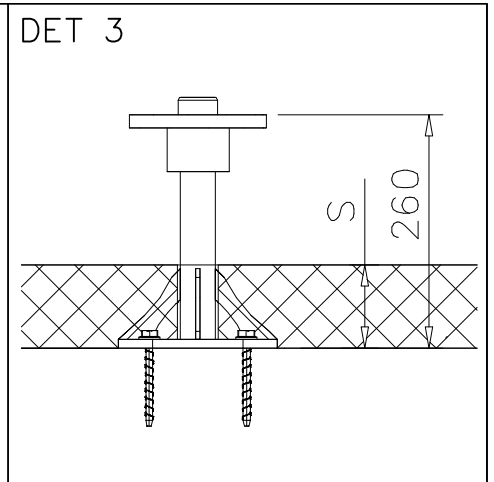
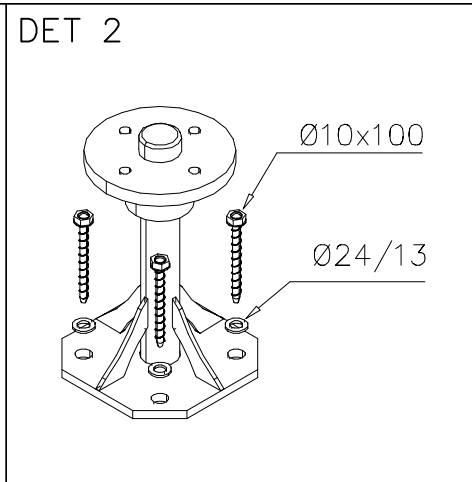
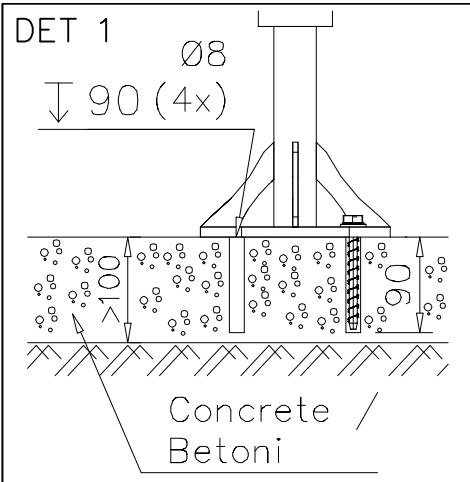

DET 13

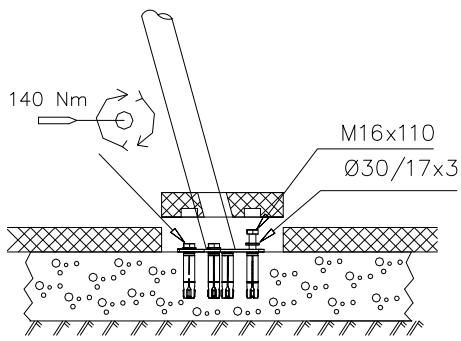

DET 14



DET 15



DET 16

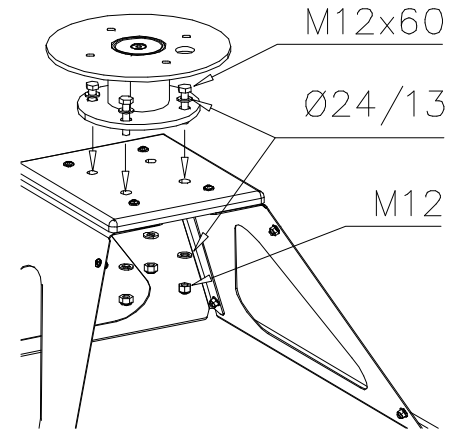

DET 17

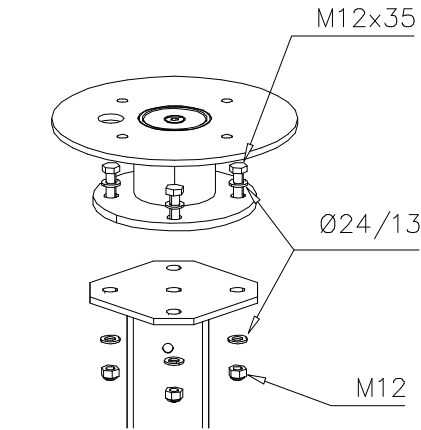

DET 18

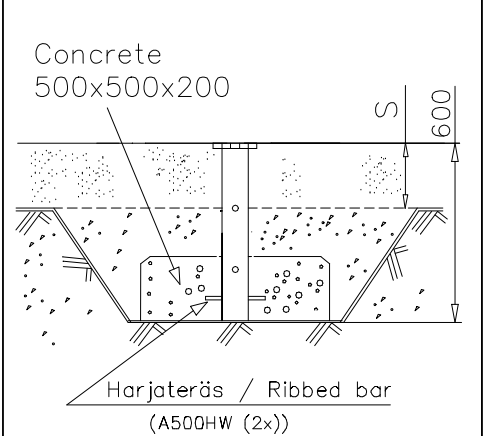

DET 19

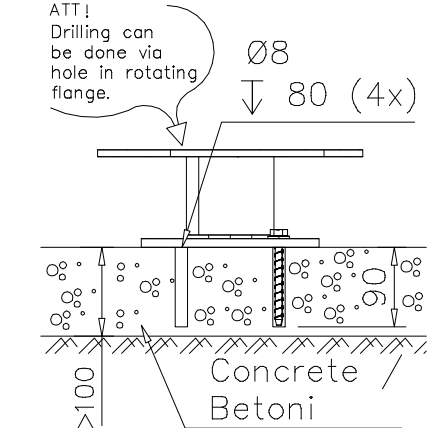

DET 20

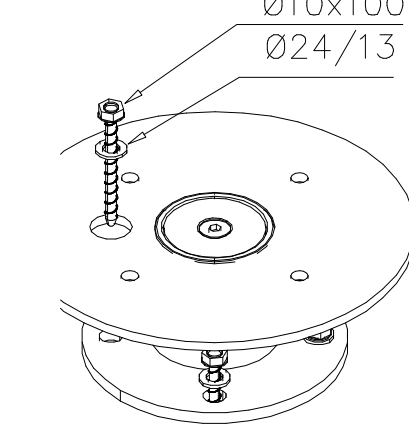

DET 21

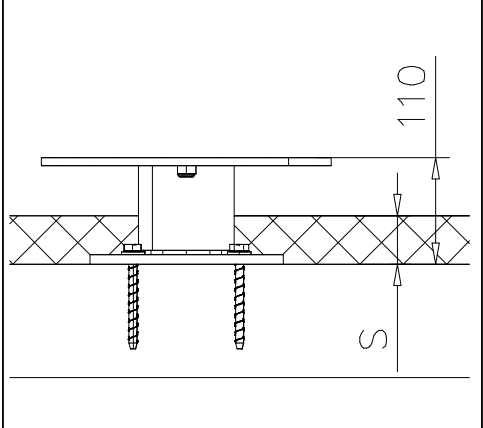

DET 22

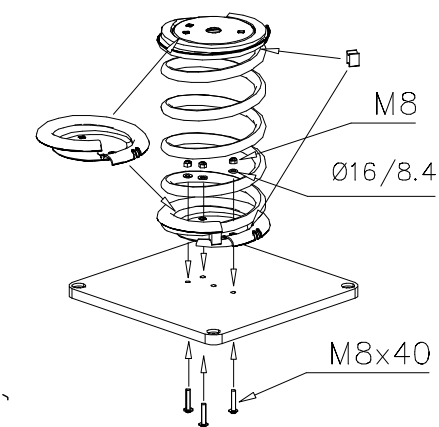



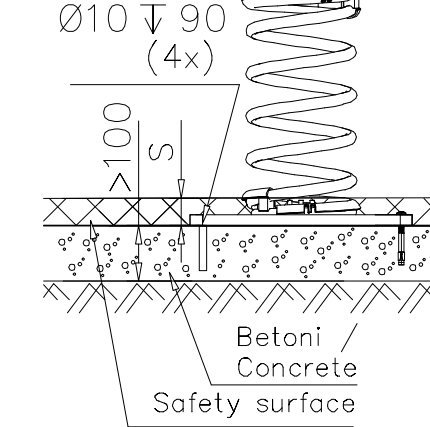

DET 23

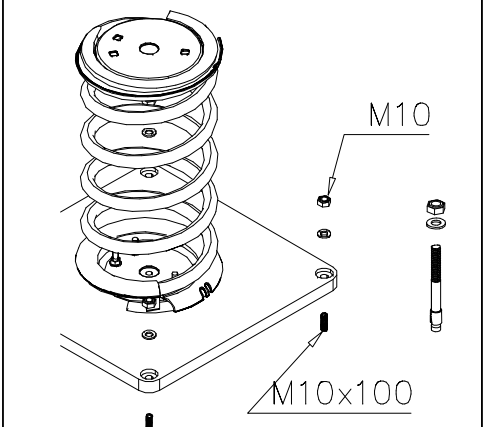

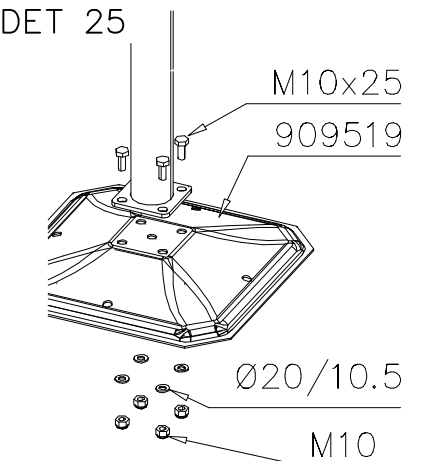
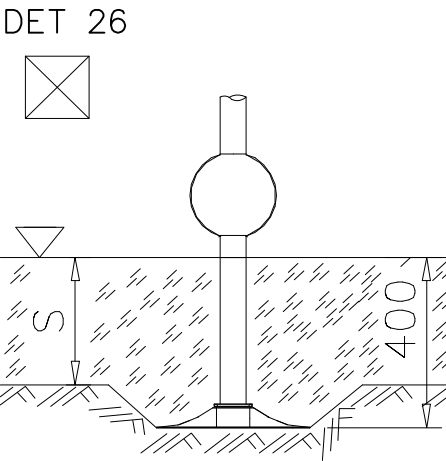
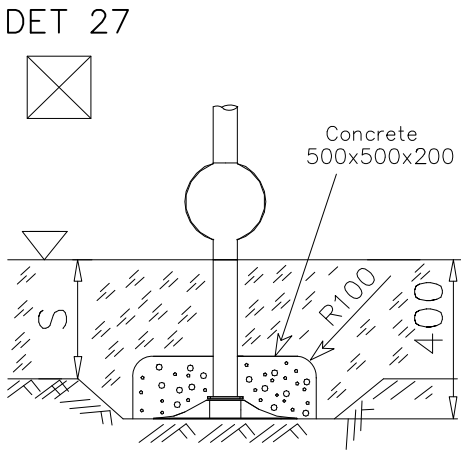
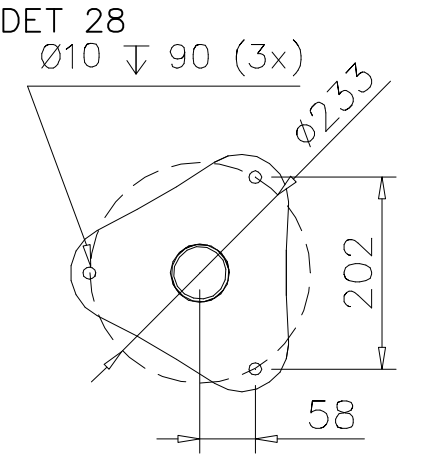
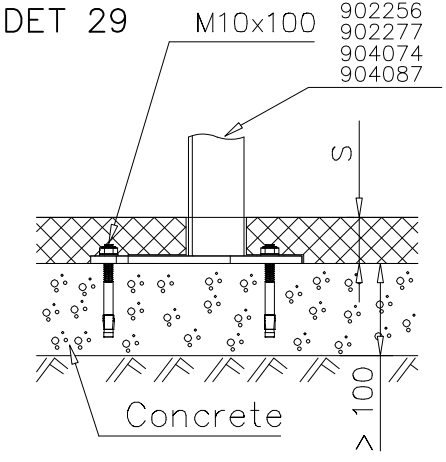
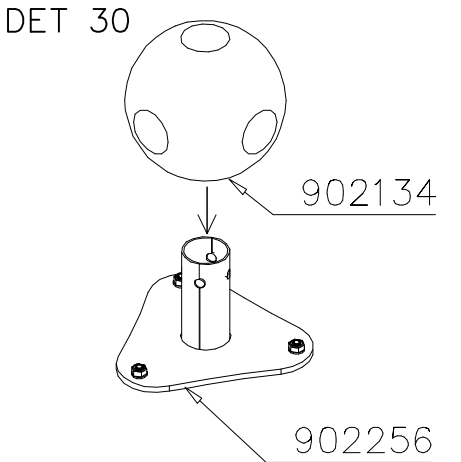
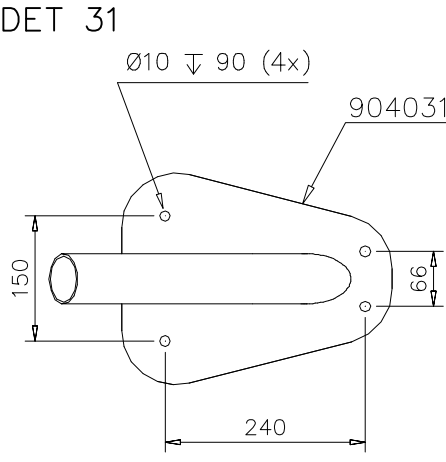
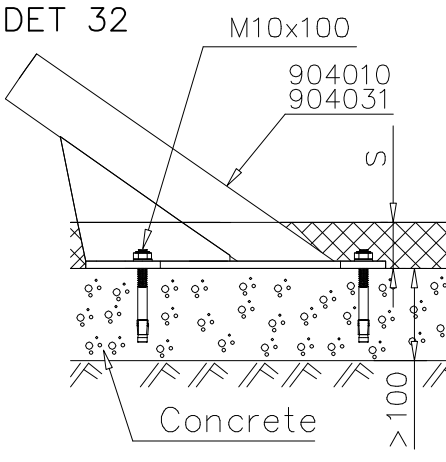
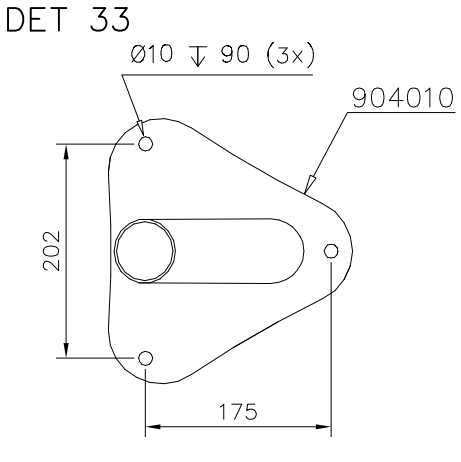
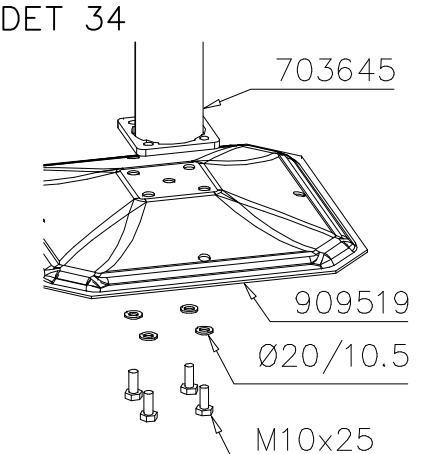
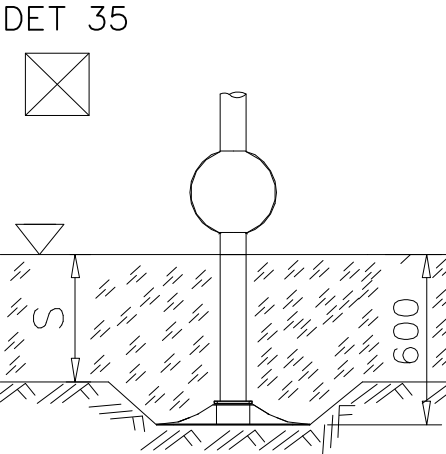
DET 24

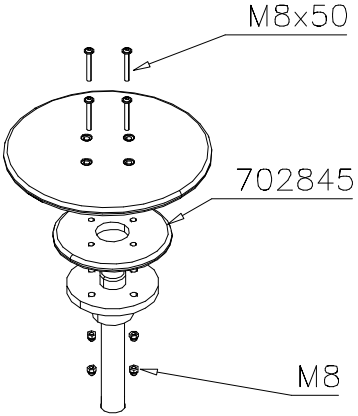
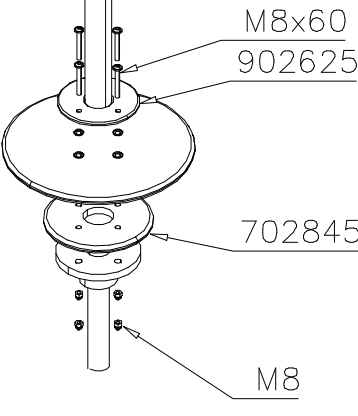

<p>DET 25</p>  <p>M10x25 909519</p> <p>Ø20/10.5 M10</p>	<p>DET 26</p>  <p>Concrete 500x500x200</p> <p>R100</p> <p>400</p>	<p>DET 27</p>  <p>Concrete 500x500x200</p> <p>R100</p> <p>400</p>
<p>DET 28</p>  <p>Ø10 ↓ 90 (3x)</p> <p>Ø233</p> <p>202</p> <p>58</p>	<p>DET 29</p>  <p>M10x100</p> <p>902256 902277 904074 904087</p> <p>Concrete</p> <p>100</p>	<p>DET 30</p>  <p>902134</p> <p>902256</p>
<p>DET 31</p>  <p>Ø10 ↓ 90 (4x)</p> <p>904031</p> <p>150</p> <p>240</p> <p>66</p>	<p>DET 32</p>  <p>M10x100</p> <p>904010 904031</p> <p>Concrete</p> <p>100</p>	<p>DET 33</p>  <p>Ø10 ↓ 90 (3x)</p> <p>904010</p> <p>202</p> <p>175</p>
<p>DET 34</p>  <p>703645</p> <p>909519</p> <p>Ø20/10.5</p> <p>M10x25</p>	<p>DET 35</p>  <p>600</p>	<p>DET 36</p> 

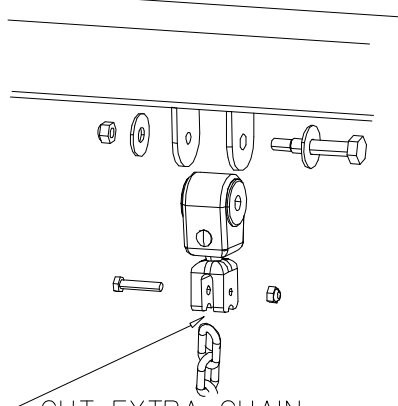
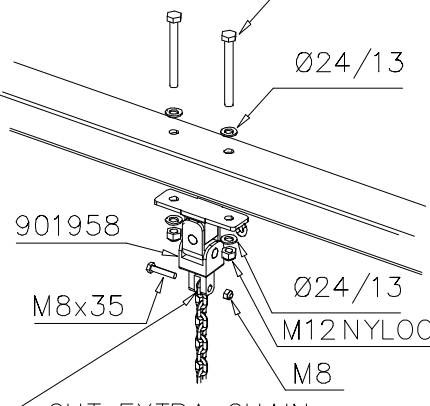
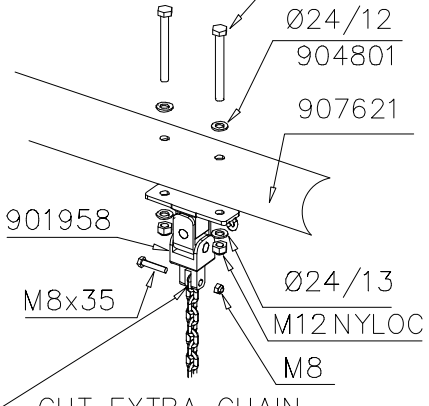
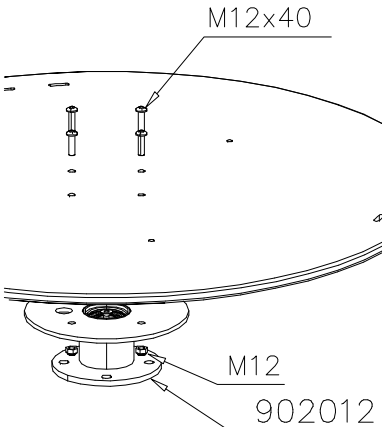
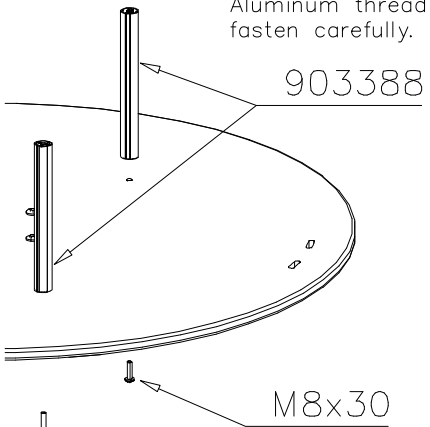
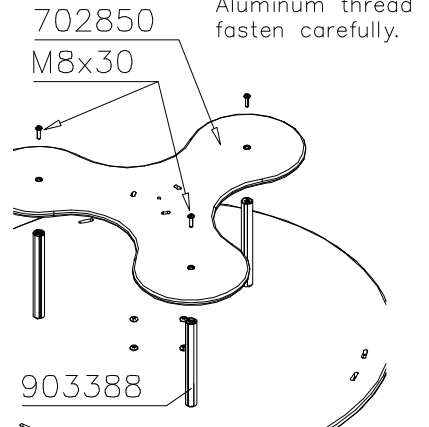
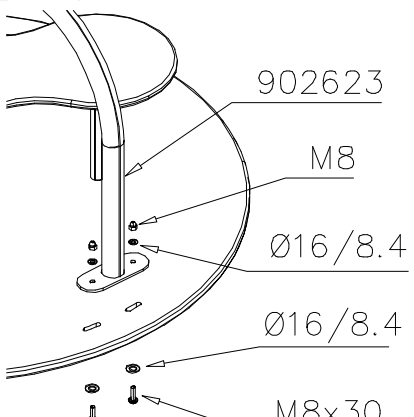
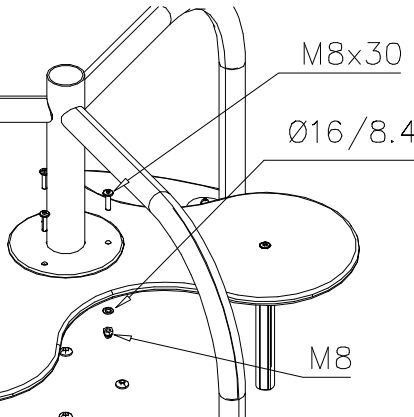
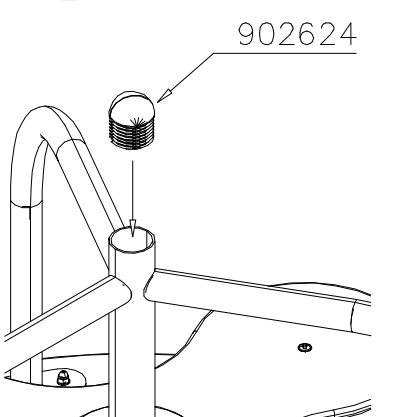
<p>DET 1</p>  <p>M8x50</p> <p>702845</p> <p>M8</p>	<p>DET 2</p>  <p>M8x60</p> <p>902625</p> <p>702845</p> <p>M8</p>	<p>DET 3</p> 
<p>DET 4</p>  <p>CUT EXTRA CHAIN</p>	<p>DET 5</p>  <p>M12x110</p> <p>Ø24/13</p> <p>901958</p> <p>M8x35</p> <p>Ø24/13</p> <p>M12 NYLOC</p> <p>M8</p> <p>CUT EXTRA CHAIN</p>	<p>DET 6</p>  <p>M12x120</p> <p>Ø24/12</p> <p>904801</p> <p>907621</p> <p>901958</p> <p>M8x35</p> <p>Ø24/13</p> <p>M12 NYLOC</p> <p>M8</p> <p>CUT EXTRA CHAIN</p>
<p>DET 7</p>  <p>M12x40</p> <p>M12</p> <p>902012</p>	<p>DET 8</p> <p>NOTE: Aluminum thread fasten carefully.</p>  <p>903388</p> <p>M8x30</p>	<p>DET 9</p> <p>NOTE: Aluminum thread fasten carefully.</p>  <p>702850</p> <p>M8x30</p> <p>903388</p>
<p>DET 10</p>  <p>902623</p> <p>M8</p> <p>Ø16/8.4</p> <p>Ø16/8.4</p> <p>M8x30</p>	<p>DET 11</p>  <p>M8x30</p> <p>Ø16/8.4</p> <p>M8</p>	<p>DET 12</p>  <p>902624</p>

# WINAM GROUP

## CLOXX / FINNO ABC



# PARTS

DATE: 12.9.2017



<p>DET 13</p> <p>M10x50 Ø20/10.5 M10</p>	<p>DET 14</p> <p>M10x40 Ø20/10.5 M10</p>	<p>DET 15</p> <p>M10x40 (901487) M10 (909637) Ø20/10.5x2 (901302)</p>
<p>DET 16</p> <p>903572 903567 M8x60 GLUE</p>	<p>DET 17</p> <p>M12x90 901994 M12</p>	<p>DET 18</p> <p>M12x120 903574 M12</p>
<p>DET 19</p> <p>M12x90 M12 902157</p>	<p>DET 20</p> <p>M12 901994 M12x120</p>	<p>DET 21</p> <p>M8x60 M8 905067</p>
<p>DET 22</p> <p>703062 M8x60 GLUE</p>	<p>DET 23</p>	<p>DET 24</p> <p>901958 903577</p>

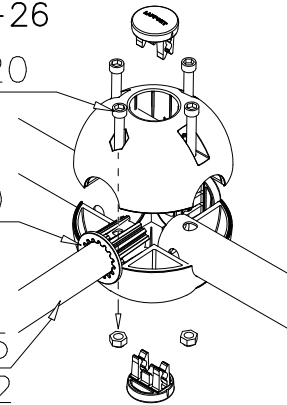
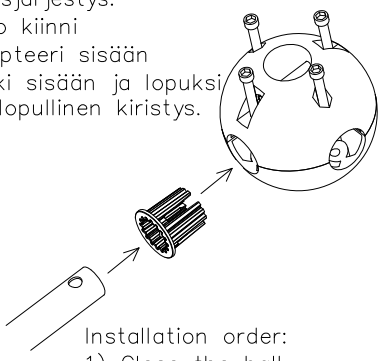
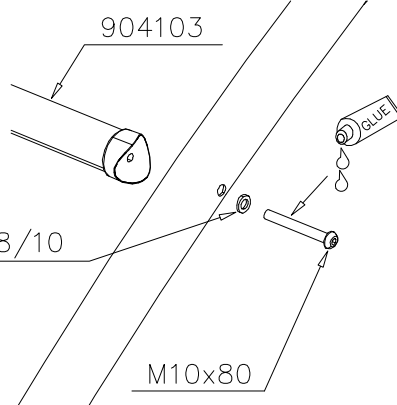
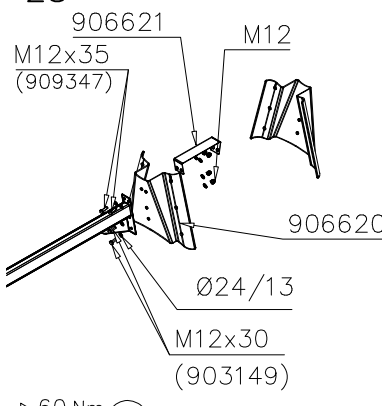
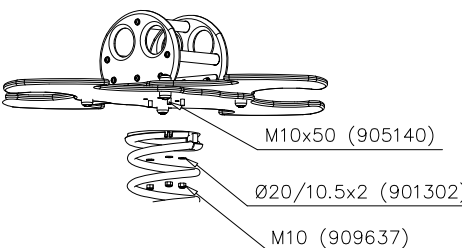
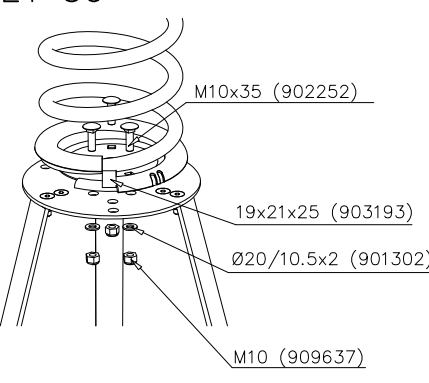
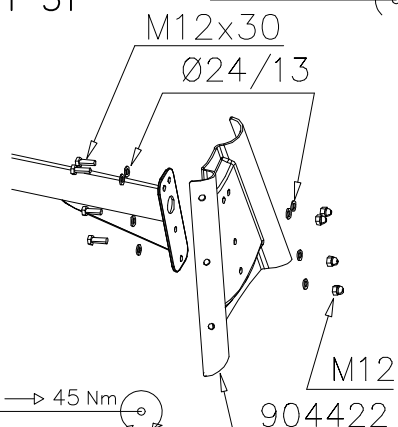
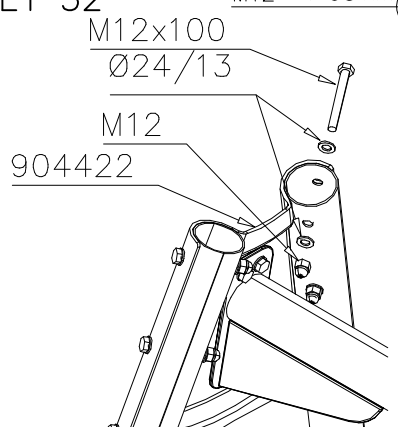
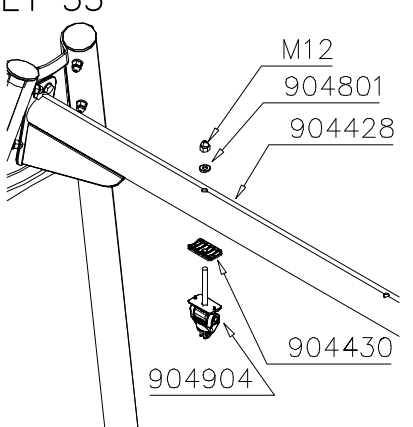
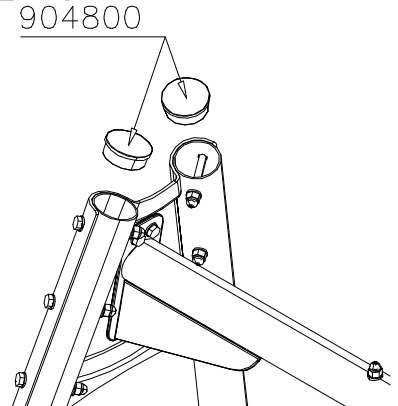
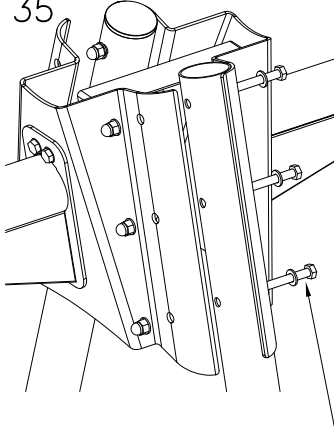

<p>DET 25-26</p> <p>M12x120</p> <p>904100</p> <p>904015</p> <p>904102</p> <p>Kun putken pää osuu adapterin kynsiin, adapteri tiukentuu paikoilleen.</p> 	<p>Asennusjärjestys:</p> <ol style="list-style-type: none"> <li>1) Pallo kiinni</li> <li>2) Adapteri sisään</li> <li>3) putki sisään ja lopuksi pallon lopullinen kiristys.</li> </ol> <p>Installation order:</p> <ol style="list-style-type: none"> <li>1) Close the ball</li> <li>2) Insert adapter</li> <li>3) Insert tube and tighten screws.</li> </ol> 	<p>DET 27</p> <p>904103</p> <p>Ø18/10</p> <p>M10x80</p> 
<p>DET 28</p> <p>906621</p> <p>M12x35 (909347)</p> <p>M12</p> <p>906620</p> <p>Ø24/13</p> <p>M12x30 (903149)</p> <p>M12 → 60 Nm</p> 	<p>DET 29</p> <p>M10x50 (905140)</p> <p>Ø20/10.5x2 (901302)</p> <p>M10 (909637)</p> 	<p>DET 30</p> <p>M10x35 (902252)</p> <p>19x21x25 (903193)</p> <p>Ø20/10.5x2 (901302)</p> <p>M10 (909637)</p> 
<p>DET 31</p> <p>M12 → 60 Nm</p> <p>M12x30</p> <p>Ø24/13</p> <p>M12</p> <p>904422</p> <p>M10 → 45 Nm</p> 	<p>DET 32</p> <p>M12 → 60 Nm</p> <p>M12x100</p> <p>Ø24/13</p> <p>M12</p> <p>904422</p> 	<p>DET 33</p> <p>M12</p> <p>904801</p> <p>904428</p> <p>904430</p> <p>904904</p> 
<p>DET 34</p> <p>904800</p> 	<p>DET 35</p> <p>M12x110</p> 	<p>DET 36</p> 

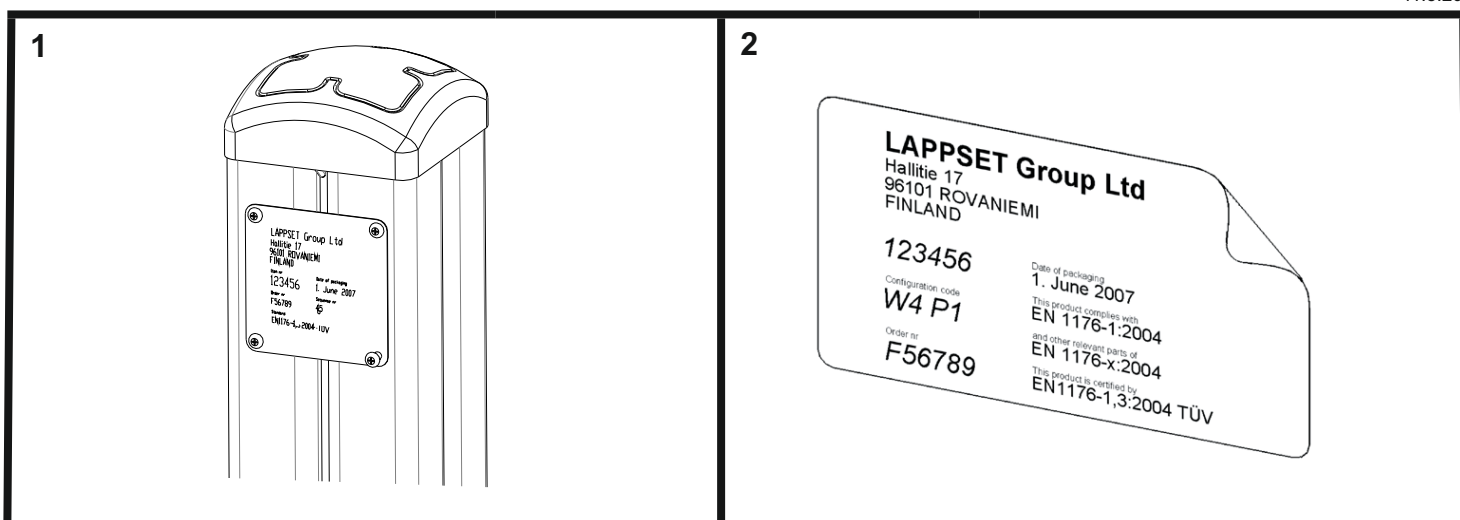

### Tuotekyltti tulee tuotteen mukana yhdellä seuraavista tavoista:

#### 1) Metallinen tuotekyltti ja kiinnitysruuvit

- Kiinnitä tuotekyltti ruuveilla tolppaan noin 2 metrin korkeuteen kuvan 2 mukaisesti.

#### 2) Tuotekylttitarra

- Puhdista maalattu metalli- tai vaneripinta pölystä ja kosteudesta. Liimaa tarra kuvan 3 mukaisesti.
- Huom. Älä kiinnitä tarraa karheapintaiseen laminaattiin tai maalattuun puuhun.

### Vår produktmärkning levereras på ett av följande sätt:

#### 1) Produktskylt i metall

- Fäst skylten med de medföljande skruvarna

#### 2) Självhäftande produktetikett

- Rengör den pulverlackerad metallytan eller laminatytans åttanblirfrifrånsmutsochfukt. Fäst etiketten enligt fig. 3.
- Obs! Fäst ej etiketten på detaljer med skrovlig yta eller på målat trä.

### Product label is delivered by one of following ways:

#### 1) Metal product label and screws

- Fasten the label with screws.

#### 2) Label sticker

- Clean the painted metal or plywood surface from dirt and moisture. Fasten the sticker as shown in the figure 3.
- Note. Do not attach the sticker to rough surfaced laminate or painted wood.

### La plaque d'informations produit est livrée sous l'une de ces 3 formes :

#### 1) Plaque métallique et vis

- Fixez la plaque à l'aide des vis.

#### 2) Etiquette autocollante

- Avant de coller l'étiquette, nettoyez le composant métallique peint ou la plaque de contreplaqué, de toute saleté. La surface doit être sèche (voir image 3).
- Attention, ne pas coller l'étiquette sur une surface lamellé-collée irrégulière ou sur du bois peint.

### Die Auslieferung des Produktaufklebers erfolgt auf eine dieser Arten:

#### 1) Produkt-Schild aus Metall incl. Schrauben

- Die Befestigung des Schildes erfolgt mittels der Schrauben.

#### 2) Aufkleber

- Entfernen Sie zunächst Schmutz und Feuchtigkeit vom lackierten Metall bzw. von der Holzoberfläche und bringen Sie den Aufkleber wie im Bild oben rechts beschrieben auf den gesäuberten Untergrund auf.
- Beachten Sie: Bringen Sie den Aufkleber nicht auf raues laminiertes oder lackiertes Holz an.

# WINAM GROUP GROUNDING

# 705101

DATE: 1.9.2017

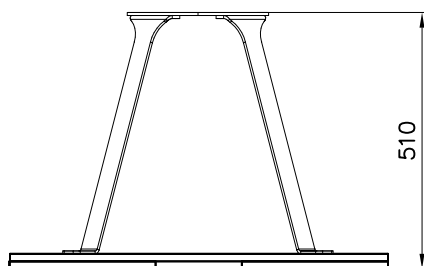
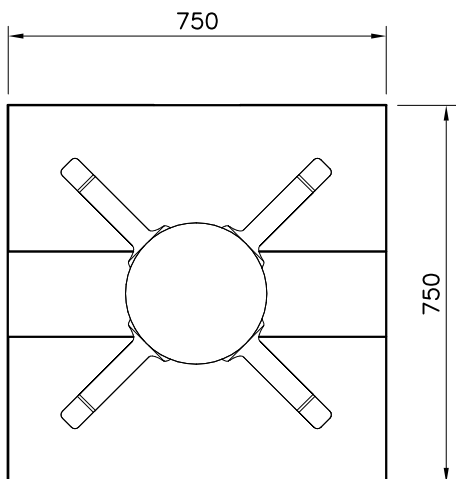
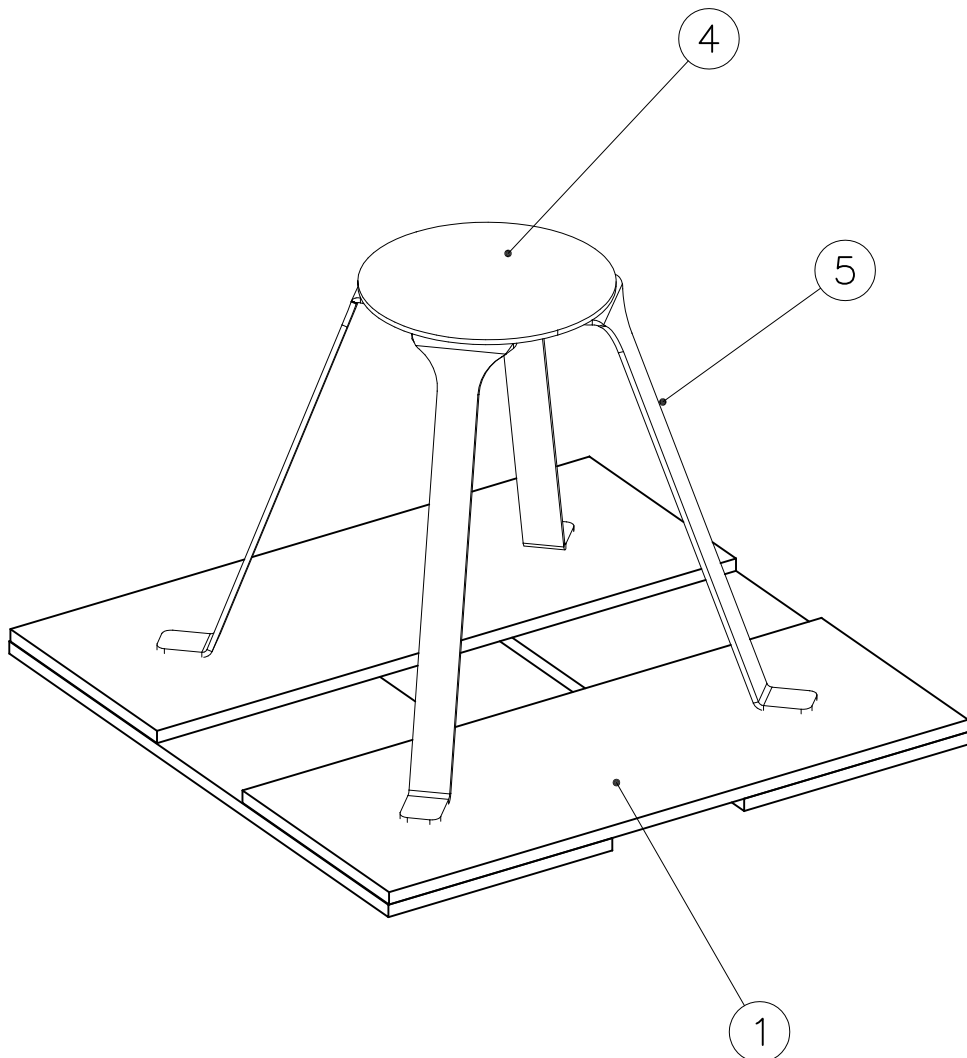

①	707138	PCS	②	900958	PCS
		4			8
	260x595			M10x30	
③	902232	PCS	④	905993	PCS
		4			1
	M10x55				
⑤	906000	PCS	⑥	909255	PCS
		4			8
				Ø30/10.5	
⑦	980161	PCS			PCS
		12			
	M10				
		PCS			PCS
		PCS			PCS
		PCS			PCS

# WINAM GROUP GROUNDING

# 705101

DATE: 1.9.2017



DET 1

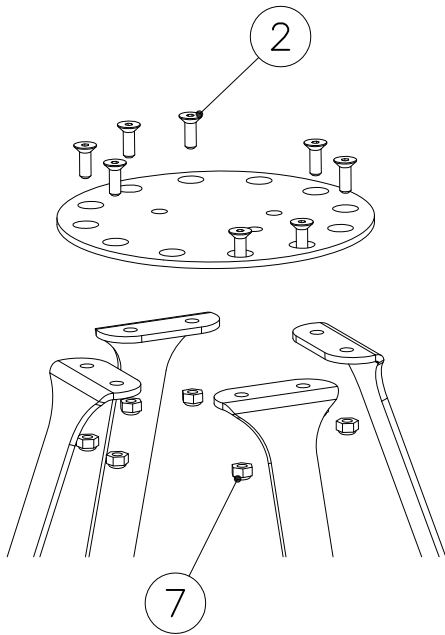

DET 2

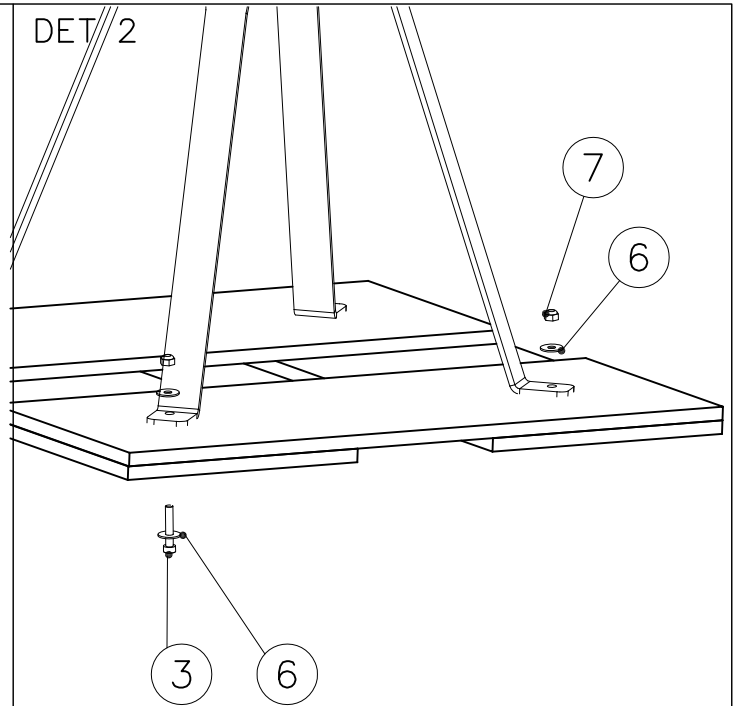



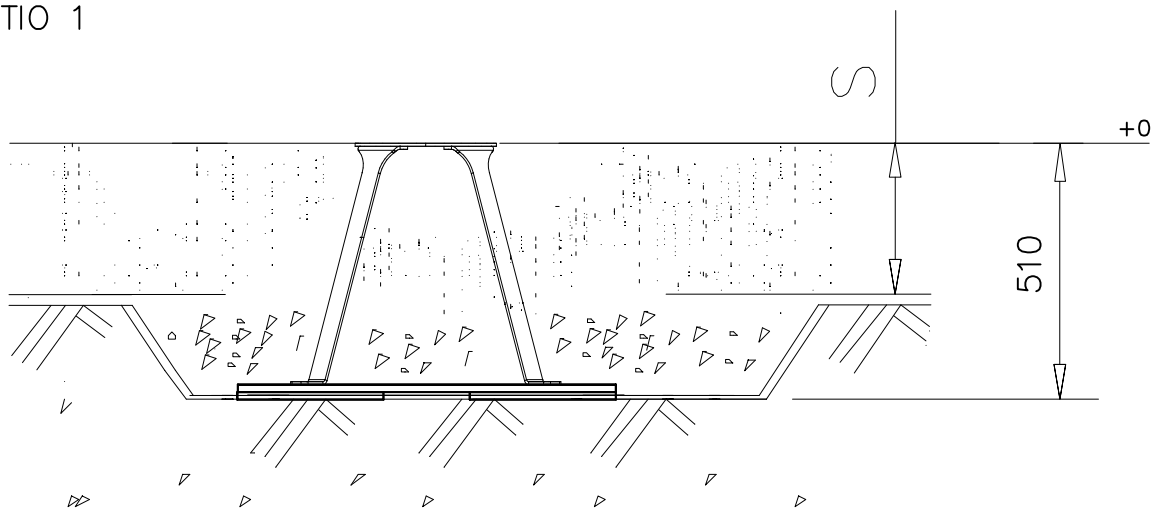

DET 3 OPTIO 1

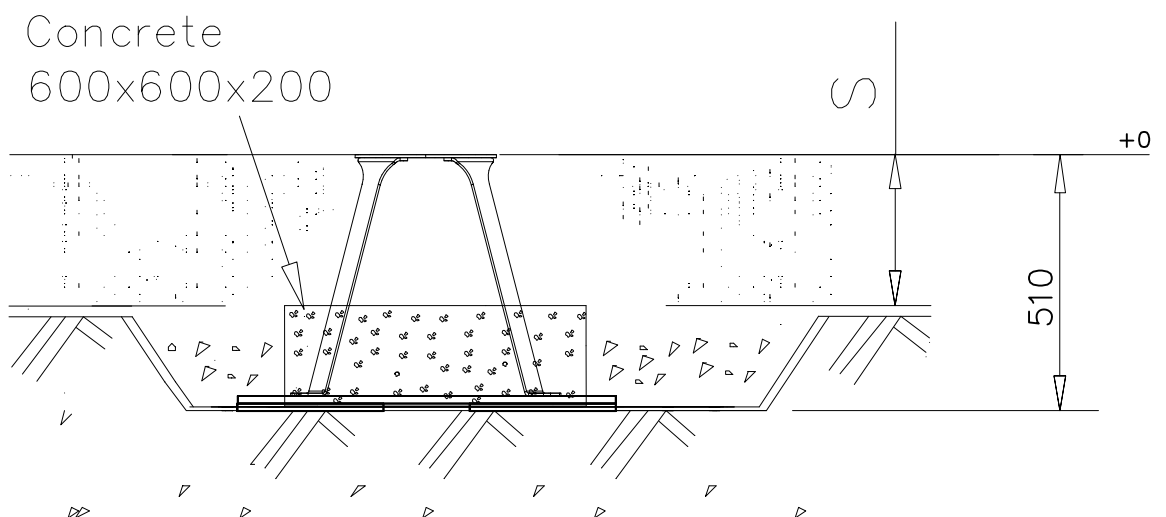

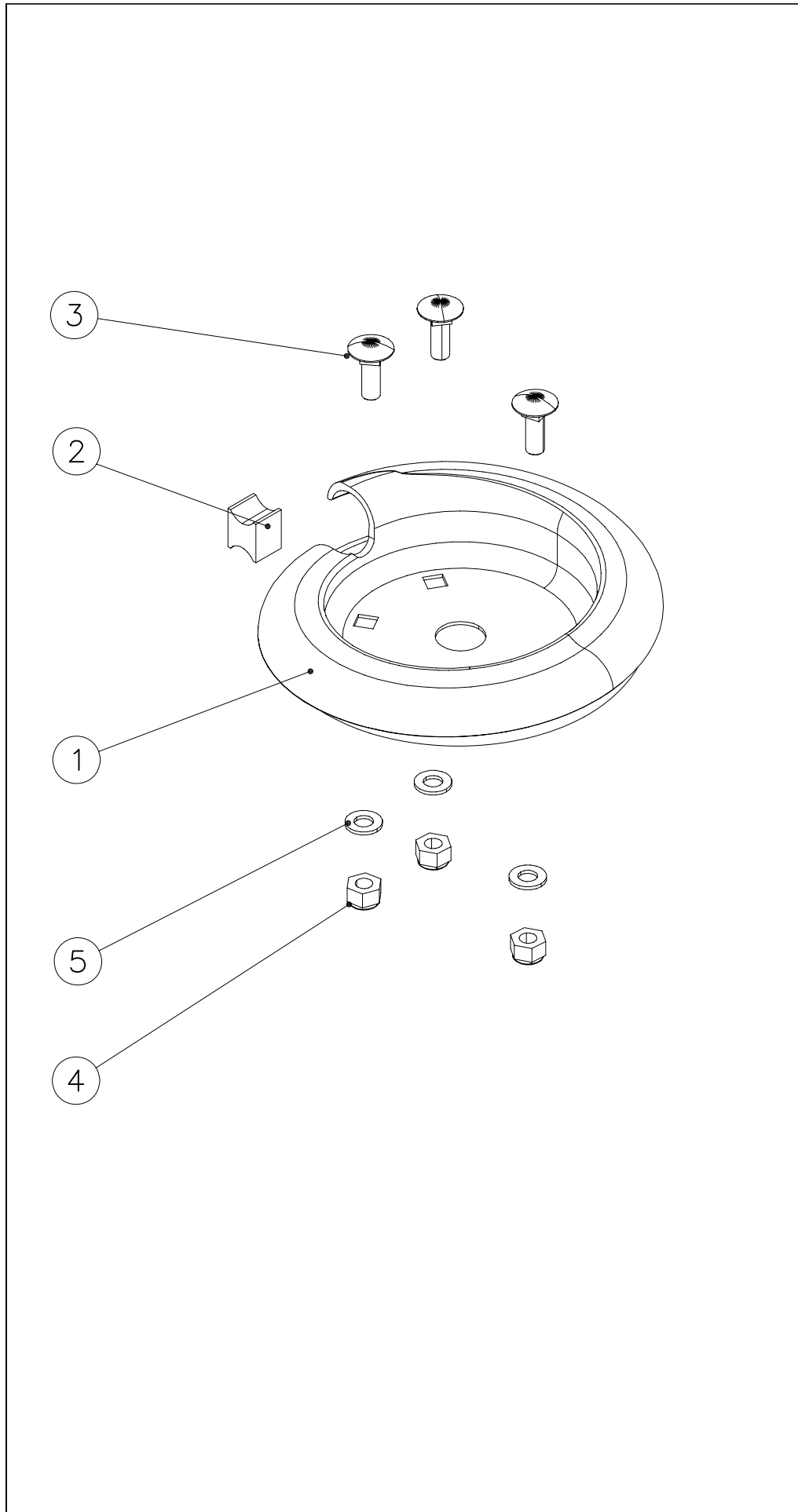
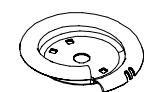
DET 3 OPTIO 2 (WITH CONCRETE)

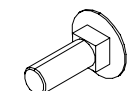

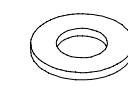
	①	PCS	②	PCS
		1		1
			19x21x25	
	③	PCS	④	PCS
		3		3
	M10x35		M10	
	⑤	PCS		PCS
		3		
	Ø20/10.5			
		PCS		PCS
	PCS		PCS	
	PCS		PCS	
	PCS		PCS	
	PCS		PCS	

## Jousen ja kiinnityslevyn kiinnittäminen Fixing the spring and gable plate

Aseta jousen kiinnityslevy jousen kierteiden väliin.  
Place the spring berch between the bottom coils



Kierrä kiinnityslevyä kohti kiinnitysalustaa.  
Turn the spring berch towards the anchor



Aseta muovipala kiinnityslevyn kierteen aloitus- ja lopetus osan väliin kuvan osoittamalla tavalla.

Place the plastic piece between coils as shown below



Kierrä kiinnitys levyä myötäpäivää, kunnes muovipala koskettaa jousen kierrettä.

Turn the spring berch clockwise until the plastic piece is in contact to coils below and underneath.

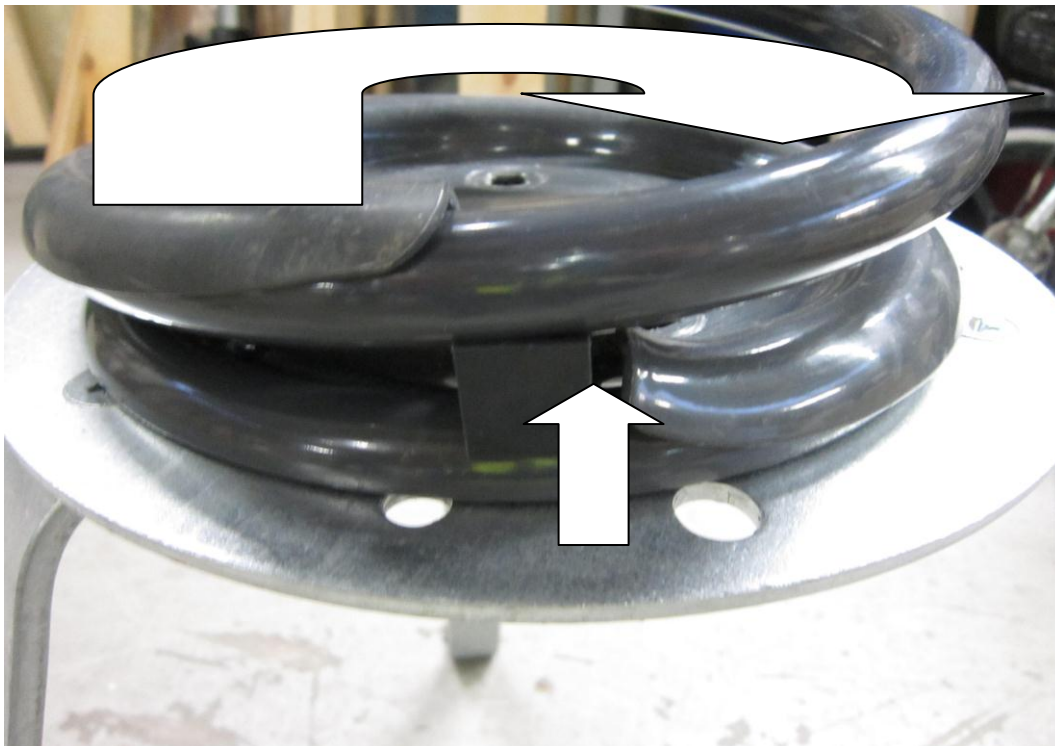

Kohdista kiinnityslevyn pulttien reiät ja perustuksen kiinnitysreiät kohdalleen. 5mm – 10mm rako ennen kiristystä.

Center the fixing holes of anchor and spring berch. There should be 5-10 mm gap between the parts prior to tightening.

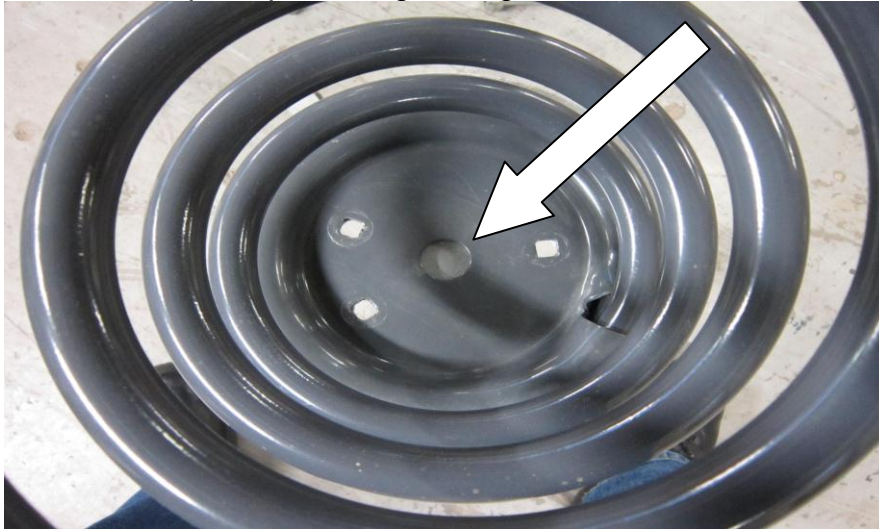

Kiristä huolellisesti pultit vuorotellen kiristäen. Kiristuksen jälkeen osien välillä saa olla korkeintaan 1mm rako keskireiästä katsoen.

Tighten the bolts gradually, about 1 turn at the time. After the tightening, there must not be more than 1mm gap between the parts

