

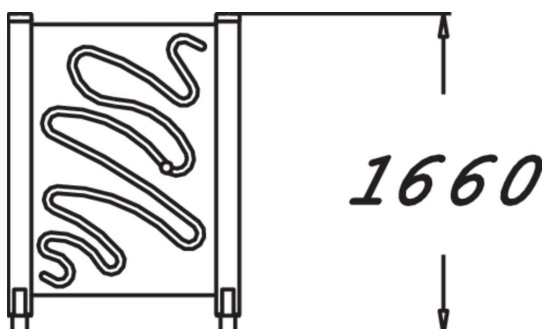

Fitness equipment intended for seniors, consisting of two upright posts holding a laminate panel with a small movable ball. The total height is 1,655 mm. The Serpentine Path is an exciting-looking device that improves shoulder and elbow joint mobility. The idea is to move the ball up and down using one hand. Reaching up high helps to maintain posture.

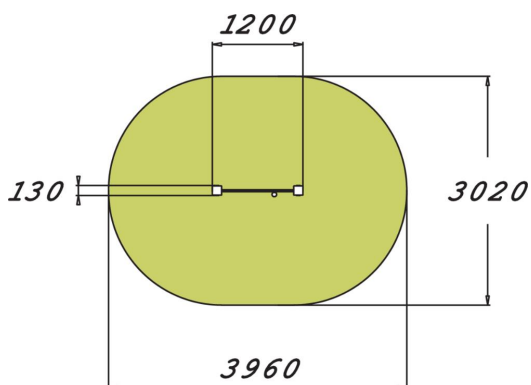

Product length, mm	1200
Product width, mm	130
Product height, mm	1655
Safety info	EN 16630, EN 1176-1 TÜV
Installation time (for 1), H	4
Foundation options	Deep mounting Surface mounting